



Bid Number/बोली क्रमांक (बिड संख्या):
GEM/2023/B/3929851
Dated/दिनांक : 08-09-2023

Bid Document/ बिड दस्तावेज़

Bid Details/बिड विवरण	
Bid End Date/Time/बिड बंद होने की तारीख/समय	22-09-2023 11:00:00
Bid Opening Date/Time/बिड खुलने की तारीख/समय	22-09-2023 11:30:00
Bid Offer Validity (From End Date)/बिड पेशकश वैधता (बंद होने की तारीख से)	60 (Days)
Ministry/State Name/मंत्रालय/राज्य का नाम	Ministry Of Chemicals And Fertilizers
Department Name/विभाग का नाम	Department Of Chemicals And Petrochemicals
Organisation Name/संगठन का नाम	Hindustan Organic Chemicals Limited
Office Name/कार्यालय का नाम	Ambalamugal,ernakulam
Total Quantity/कुल मात्रा	16
Item Category/मद केटेगरी	Complete Tray Assembly for C 2003, Tray nos: 1, 3 & 5 to 14 (Q3) , Complete Tray Assembly for C 2003, Tray nos: 16, 18 & 19 (Q3) , Complete Tray Assembly for C 2003, Tray no. 20 (Q3)
Years of Past Experience Required for same/similar service/उन्हीं/समान सेवाओं के लिए अपेक्षित विगत अनुभव के वर्ष	3 Year (s)
MSE Exemption for Years Of Experience/अनुभव के वर्षों से एमएसई छूट/ and Turnover/टर्नओवर के लिए एमएसई को छूट प्राप्त है	Yes
Startup Exemption for Years of Experience and Turnover/ अनुभव के वर्षों से स्टार्टअप छूट	No
Document required from seller/विक्रेता से मांगे गए दस्तावेज़	Experience Criteria,Past Performance,Bidder Turnover,Certificate (Requested in ATC),OEM Authorization Certificate,Additional Doc 1 (Requested in ATC),Compliance of BoQ specification and supporting document *In case any bidder is seeking exemption from Experience / Turnover Criteria, the supporting documents to prove his eligibility for exemption must be uploaded for evaluation by the buyer
Past Performance/विगत प्रदर्शन	80 %
Bid to RA enabled/बिड से रिवर्स नीलामी सक्रिय किया	No
Type of Bid/बिड का प्रकार	Two Packet Bid

Bid Details/बिड विवरण

Primary product category	Complete Tray Assembly for C 2003, Tray nos: 1, 3 & 5 to 14
Time allowed for Technical Clarifications during technical evaluation/तकनीकी मूल्यांकन के दौरान तकनीकी स्पष्टीकरण हेतु अनुमत समय	2 Days
Inspection Required (By Empanelled Inspection Authority / Agencies pre-registered with GeM)	No
Evaluation Method/मूल्यांकन पद्धति	Total value wise evaluation
Financial Document Required/वित्तीय दस्तावेज की आवश्यकता है।	Yes

EMD Detail/ईएमडी विवरण

Required/आवश्यकता	No
-------------------	----

ePBG Detail/ईपीबीजी विवरण

Required/आवश्यकता	No
-------------------	----

Splitting/विभाजन

Bid splitting not applied/बोली विभाजन लागू नहीं किया गया.

MII Purchase Preference/एमआईआई खरीद वरीयता

MII Purchase Preference/एमआईआई खरीद वरीयता	Yes
--	-----

MSE Purchase Preference/एमएसई खरीद वरीयता

MSE Purchase Preference/एमएसई खरीद वरीयता	Yes
---	-----

1. If the bidder is a Micro or Small Enterprise as per latest definitions under MSME rules, the bidder shall be exempted from the requirement of "Bidder Turnover" criteria and "Experience Criteria" subject to meeting of quality and technical specifications. If the bidder is OEM of the offered products, it would be exempted from the "OEM Average Turnover" criteria also subject to meeting of quality and technical specifications. In case any bidder is seeking exemption from Turnover / Experience Criteria, the supporting documents to prove his eligibility for exemption must be uploaded for evaluation by the buyer.
2. Experience Criteria: In respect of the filter applied for experience criteria, the Bidder or its OEM {themselves or through reseller(s)} should have regularly, manufactured and supplied same or similar Category Products to any Central / State Govt Organization / PSU / Public Listed Company for number of Financial years as indicated above in the bid document before the bid opening date. Copies of relevant contracts to be submitted along with bid in

support of having supplied some quantity during each of the Financial year. In case of bunch bids, the category of primary product having highest value should meet this criterion.

3. Preference to Make In India products (For bids < 200 Crore):Preference shall be given to Class 1 local supplier as defined in public procurement (Preference to Make in India), Order 2017 as amended from time to time and its subsequent Orders/Notifications issued by concerned Nodal Ministry for specific Goods/Products. The minimum local content to qualify as a Class 1 local supplier is denoted in the bid document. If the bidder wants to avail the Purchase preference, the bidder must upload a certificate from the OEM regarding the percentage of the local content and the details of locations at which the local value addition is made along with their bid, failing which no purchase preference shall be granted. In case the bid value is more than Rs 10 Crore, the declaration relating to percentage of local content shall be certified by the statutory auditor or cost auditor, if the OEM is a company and by a practicing cost accountant or a chartered accountant for OEMs other than companies as per the Public Procurement (preference to Make-in -India) order 2017 dated 04.06.2020. Only Class-I and Class-II Local suppliers as per MII order dated 4.6.2020 will be eligible to bid. Non - Local suppliers as per MII order dated 04.06.2020 are not eligible to participate. However, eligible micro and small enterprises will be allowed to participate .The buyers are advised to refer the OM No.F.1/4/2021-PPD dated 18.05.2023.

[OM No.1 4 2021 PPD dated 18.05.2023](#) for compliance of Concurrent application of Public Procurement Policy for Micro and Small Enterprises Order, 2012 and Public Procurement (Preference to Make in India) Order, 2017.

4. Purchase preference to Micro and Small Enterprises (MSEs): Purchase preference will be given to MSEs as defined in Public Procurement Policy for Micro and Small Enterprises (MSEs) Order, 2012 dated 23.03.2012 issued by Ministry of Micro, Small and Medium Enterprises and its subsequent Orders/Notifications issued by concerned Ministry. If the bidder wants to avail the Purchase preference, the bidder must be the manufacturer of the offered product in case of bid for supply of goods. Traders are excluded from the purview of Public Procurement Policy for Micro and Small Enterprises. In respect of bid for Services, the bidder must be the Service provider of the offered Service. Relevant documentary evidence in this regard shall be uploaded along with the bid in respect of the offered product or service. If L-1 is not an MSE and MSE Seller (s) has/have quoted price within L-1+ 15% (Selected by Buyer)of margin of purchase preference /price band defined in relevant policy, such Seller shall be given opportunity to match L-1 price and contract will be awarded for 25%(selected by Buyer) percentage of total QUANTITY.The buyers are advised to refer the OM No.F.1/4/2021-PPD dated 18.05.2023

[OM No.1 4 2021 PPD dated 18.05.2023](#) for compliance of Concurrent application of Public Procurement Policy for Micro and Small Enterprises Order, 2012 and Public Procurement (Preference to Make in India) Order, 2017.

5. Past Performance: The Bidder or its OEM {themselves or through re-seller(s)} should have supplied same or similar Category Products for 80% of bid quantity, in at least one of the last three Financial years before the bid opening date to any Central / State Govt Organization / PSU / Public Listed Company. Copies of relevant contracts (proving supply of cumulative order quantity in any one financial year) to be submitted along with bid in support of quantity supplied in the relevant Financial year. In case of bunch bids, the category related to primary product having highest bid value should meet this criterion.

Complete Tray Assembly For C 2003, Tray Nos: 1, 3 & 5 To 14 (12 set)

(Minimum 50% and 20% Local Content required for qualifying as Class 1 and Class 2 Local Supplier respectively/क्रमशः श्रेणी 1 और श्रेणी 2 के स्थानीय आपूर्तिकर्ता के रूप में अर्हता प्राप्त करने के लिए आवश्यक)

Technical Specifications/तकनीकी विशिष्टियाँ

Buyer Specification Document/क्रेता विशिष्टि दस्तावेज़	Download
--	--------------------------

Additional Specification Documents/अतिरिक्त विशिष्टि दस्तावेज़

DrawingDocument1	View
DrawingDocument2	View

Consignees/Reporting Officer/परेषिती/रिपोर्टिंग अधिकारी and/ तथा Quantity/मात्र

S.No./क्र. सं.	Consignee Reporting/Officer/ परेषिती/रिपोर्टिंग अधिकारी	Address/पता	Quantity/मात्र	Delivery Days/डिलीवरी के दिन
1	Abhilash M S	682302,HINDUSTAN ORGANIC CHEMICALS LTD, AMBALAMUGAL ERNAKULAM	12	45

Complete Tray Assembly For C 2003, Tray Nos: 16, 18 & 19 (3 set)

(Minimum 50% and 20% Local Content required for qualifying as Class 1 and Class 2 Local Supplier respectively/क्रमशः श्रेणी 1 और श्रेणी 2 के स्थानीय आपूर्तिकर्ता के रूप में अर्हता प्राप्त करने के लिए आवश्यक)

Technical Specifications/तकनीकी विशिष्टियाँ

Buyer Specification Document/क्रेता विशिष्टि दस्तावेज़	Download
--	--------------------------

Consignees/Reporting Officer/परेषिती/रिपोर्टिंग अधिकारी and/ तथा Quantity/मात्र

S.No./क्र. सं.	Consignee Reporting/Officer/ परेषिती/रिपोर्टिंग अधिकारी	Address/पता	Quantity/मात्र	Delivery Days/डिलीवरी के दिन
1	Abhilash M S	682302,HINDUSTAN ORGANIC CHEMICALS LTD, AMBALAMUGAL ERNAKULAM	3	45

Complete Tray Assembly For C 2003, Tray No. 20 (1 set)

(Minimum 50% and 20% Local Content required for qualifying as Class 1 and Class 2 Local Supplier respectively/क्रमशः श्रेणी 1 और श्रेणी 2 के स्थानीय आपूर्तिकर्ता के रूप में अर्हता प्राप्त करने के लिए आवश्यक)

Technical Specifications/तकनीकी विशिष्टियाँ

Buyer Specification Document/क्रेता विशिष्टि दस्तावेज़	Download
--	--------------------------

Consignees/Reporting Officer/परेषिती/रिपोर्टिंग अधिकारी and/ तथा Quantity/मात्र

S.No./क्र. सं.	Consignee Reporting/Officer/ परेषिती/रिपोर्टिंग अधिकारी	Address/पता	Quantity/मात्रा	Delivery Days/डिलीवरी के दिन
1	Abhilash M S	682302,HINDUSTAN ORGANIC CHEMICALS LTD, AMBALAMUGAL ERNAKULAM	1	45

Buyer added Bid Specific Additional Scope of Work

S.No.क्र.सं.	Document Title	Description	Applicable/रिर्वर्स प्रभार के अनुसार जीएसटी i.r.o. Items
1	Spec Sheet View	Complete Spec Sheet	Complete Tray Assembly For C 2003, Tray Nos: 1, 3 & 5 To 14(12),Complete Tray Assembly For C 2003, Tray Nos: 16, 18 & 19(3),Complete Tray Assembly For C 2003, Tray No. 20(1)
2	Project Spec View	Project Specification for Trays	Complete Tray Assembly For C 2003, Tray Nos: 1, 3 & 5 To 14(12),Complete Tray Assembly For C 2003, Tray Nos: 16, 18 & 19(3),Complete Tray Assembly For C 2003, Tray No. 20(1)
3	Drawings View	Drawing Sheets	Complete Tray Assembly For C 2003, Tray Nos: 1, 3 & 5 To 14(12),Complete Tray Assembly For C 2003, Tray Nos: 16, 18 & 19(3),Complete Tray Assembly For C 2003, Tray No. 20(1)

The uploaded document only contains Buyer specific Additional Scope of Work and / or Drawings for the bid items added with due approval of Buyer's competent authority. Buyer has certified that these additional scope and drawings are generalized and would not lead to any restrictive bidding.

Buyer Added Bid Specific Terms and Conditions/क्रेता द्वारा जोड़ी गई बिड की विशेष शर्तें

1. Generic

OPTION CLAUSE: The Purchaser reserves the right to increase or decrease the quantity to be ordered up to 25 percent of bid quantity at the time of placement of contract. The purchaser also reserves the right to increase the ordered quantity by up to 25% of the contracted quantity during the currency of the contract at the contracted rates. Bidders are bound to accept the orders accordingly.

2. Generic

After award of contract – Successful Bidder shall have to get Detailed Design Drawings approved from buyer before starting fabrication. Successful Bidder shall submit Detailed Design Drawings for Buyer's approval, within 7 days of award of contract. Buyer shall, either approve the drawings or will provide complete list of modification required in the drawings within 7 days. Seller shall be required to ensure supply as per approved Drawings with modifications as communicated by Buyer. If there is delay from buyer side in approval of drawing- the delivery period shall be refixed without LD for the period of delay in approval of Drawing.

3. **Generic**

Bidders are advised to check applicable GST on their own before quoting. Buyer will not take any responsibility in this regards. GST reimbursement will be as per actuals or as per applicable rates (whichever is lower), subject to the maximum of quoted GST %.

4. **Generic**

Bidder shall submit the following documents along with their bid for Vendor Code Creation:

- a. Copy of PAN Card.
- b. Copy of GSTIN.
- c. Copy of Cancelled Cheque.
- d. Copy of EFT Mandate duly certified by Bank.

5. **Generic**

Data Sheet of the product(s) offered in the bid, are to be uploaded along with the bid documents. Buyers can match and verify the Data Sheet with the product specifications offered. In case of any unexplained mismatch of technical parameters, the bid is liable for rejection.

6. **Generic**

Experience Criteria: The Bidder or its OEM {themselves or through reseller(s)} should have regularly, manufactured and supplied same or similar Category Products to any Central / State Govt Organization / PSU / Public Listed Company for 3 years before the bid opening date. Copies of relevant contracts to be submitted along with bid in support of having supplied some quantity during each of the year. In case of bunch bids, the primary product having highest value should meet this criterion.

7. **Generic**

Manufacturer Authorization:Wherever Authorised Distributors/service providers are submitting the bid, Authorisation Form /Certificate with OEM/Original Service Provider details such as name, designation, address, e-mail Id and Phone No. required to be furnished along with the bid

8. **Generic**

OPTIONAL SITE VISIT:

1. The Bidder is advised to visit and examine the installation site and its surroundings and obtain for itself on its own responsibility all information that may be necessary for preparing the Bid. The costs of visiting the site shall be borne by the Bidder.

Cost should be borne by the bidder

2. The Bidder representative shall be allowed entry upon consignee premises for such visits, only upon the express conditions that the Bidder will release and indemnify the Buyer and Consignee against all liabilities arising out of such visit including death or injury, loss or damage to property, and any other loss, damage, costs, and expenses incurred as a result of such visit.

3. The Bidder shall not be entitled to hold any claim against Buyer for noncompliance due to lack of any kind of pre-requisite information as it is the sole responsibility of the Bidder to obtain all the necessary information with regard to site, surrounding, working conditions, weather etc. on its own before submission of the bid.

9. **Generic**

Supplier shall ensure that the Invoice is raised in the name of Consignee with GSTIN of Consignee only.

10. **Generic**

The successful bidder has to supply all essential accessories required for the successful installation and commissioning of the goods supplied. Besides standard accessories as per normal industry practice, following accessories must be part of supply and cost should be included in bid price:

Shall be all inclusive of cost for spares, GST, P&F, Freight, TPI etc.

11. **Generic**

1. The Seller shall not assign the Contract in whole or part without obtaining the prior written consent of buyer.
2. The Seller shall not sub-contract the Contract in whole or part to any entity without obtaining the prior written consent of buyer.
3. The Seller shall, notwithstanding the consent and assignment/sub-contract, remain jointly and severally liable and responsible to buyer together with the assignee/ sub-contractor, for and in respect of the due performance of the Contract and the Sellers obligations there under.

12. **Generic**

Without prejudice to Buyer's right to price adjustment by way of discount or any other right or remedy available to Buyer, Buyer may terminate the Contract or any part thereof by a written notice to the Seller, if:

- i) The Seller fails to comply with any material term of the Contract.
- ii) The Seller informs Buyer of its inability to deliver the Material(s) or any part thereof within the stipulated Delivery Period or such inability otherwise becomes apparent.
- iii) The Seller fails to deliver the Material(s) or any part thereof within the stipulated Delivery Period and/or to replace/rectify any rejected or defective Material(s) promptly.
- iv) The Seller becomes bankrupt or goes into liquidation.
- v) The Seller makes a general assignment for the benefit of creditors.
- vi) A receiver is appointed for any substantial property owned by the Seller.
- vii) The Seller has misrepresented to Buyer, acting on which misrepresentation Buyer has placed the Purchase Order on the Seller.

13. **Generic**

While generating invoice in GeM portal, the seller must upload scanned copy of GST invoice and the screenshot of GST portal confirming payment of GST.

14. **Scope of Supply**

Scope of supply (Bid price to include all cost components) : Only supply of Goods

15. **Turnover**

Bidder Turn Over Criteria: The minimum average annual financial turnover of the bidder during the last three years, ending on 31st March of the previous financial year, should be as indicated in the bid document. Documentary evidence in the form of certified Audited Balance Sheets of relevant periods or a certificate from the Chartered Accountant / Cost Accountant indicating the turnover details for the relevant period shall be uploaded with the bid. In case the date of constitution / incorporation of the bidder is less than 3 year old, the average turnover in respect of the completed financial years after the date of constitution shall be taken into account for this criteria.

16. **Purchase Preference (Centre)**

Purchase preference to Micro and Small Enterprises (MSEs): Purchase preference will be given to MSEs as defined in Public Procurement Policy for Micro and Small Enterprises (MSEs) Order, 2012 dated 23.03.2012 issued by Ministry of Micro, Small and Medium Enterprises and its subsequent Orders/Notifications issued by concerned Ministry. If the bidder wants to avail the Purchase preference, the bidder must be the manufacturer of the offered product in case of bid for supply of goods. Traders are excluded from the purview of Public Procurement Policy for Micro and Small Enterprises. In respect of bid for Services, the bidder must be the Service provider of the offered Service. Relevant documentary evidence in this regard shall be uploaded along with the bid in respect of the offered product or service. If L-1 is not an MSE and MSE Seller (s) has/have quoted price within L-1+ 15% of margin of purchase preference /price band defined in relevant policy, such Seller shall be given opportunity to match L-1

price and contract will be awarded for percentage of 25% of total value.

17. **Purchase Preference (Centre)**

Purchase Preference linked with Local Content (PP-LC) Policy:

The bid clause regarding "Preference to Make In India products" stands modified in this bid and shall be governed by the PPLC Policy No. FP-20013/2/2017-FP-PNG dated 17.11.2020 issued by MoP&NG as amended up to date. Accordingly, bidders with Local Content less than or equal to 20% will be treated as "Non Local Supplier". The prescribed LC shall be applicable on the date of Bid opening. Sanctions on the bidders for false / wrong declaration or not fulfilling the Local Content requirement shall be as per the PPLC policy. Further following additional provisions are added in the certification and verification of local content provision of the Preference to Make in India clause:

- i. In case of foreign bidder, certificate from the statutory auditor or cost auditor of their own office or subsidiary in India giving the percentage of local content is also acceptable. In case office or subsidiary in India does not exist or Indian office/subsidiary is not required to appoint statutory auditor or cost auditor, certificate from practicing cost accountant or practicing chartered accountant giving the percentage of local content is also acceptable.
- ii. Along with Each Invoice: The local content certificate (issued by statutory auditor on behalf of procuring company) shall be submitted along with each invoice raised. However, the % of local content may vary with each invoice while maintaining the overall % of local content for the total work/purchase of the pro-rata local content requirement. In case, it is not satisfied cumulatively in the invoices raised up to that stage, the supplier shall indicate how the local content requirement would be met in the subsequent stages.
- iii. The bidder shall submit an undertaking from the authorized signatory of bidder having the Power of Attorney along with the bid stating the bidder meets the mandatory minimum LC requirement and such undertaking shall become a part of the contract.

18. **Service & Support**

Availability of Service Centres: Bidder/OEM must have a Functional Service Centre in the State of each Consignee's Location in case of carry-in warranty. (Not applicable in case of goods having on-site warranty). If service center is not already there at the time of bidding, successful bidder / OEM shall have to establish one within 30 days of award of contract. Payment shall be released only after submission of documentary evidence of having Functional Service Centre.

19. **Service & Support**

Dedicated /toll Free Telephone No. for Service Support : BIDDER/OEM must have Dedicated/toll Free Telephone No. for Service Support.

20. **Service & Support**

Escalation Matrix For Service Support : Bidder/OEM must provide Escalation Matrix of Telephone Numbers for Service Support.

21. **Inspection**

Nominated Inspection Agency: On behalf of the Buyer organization, any one of the following Inspection Agency would be conducting inspection of stores before acceptance:
Pre-dispatch Inspection at Seller Premises (applicable only if pre-dispatch inspection clause has been selected in ATC):

M/S. BUREAU VERITAS (INDIA) PVT. LTD

Post Receipt Inspection at consignee site before acceptance of stores:
M/s. Hindustan Organic Chemicals Ltd

22. **Inspection**

Pre-dispatch inspection at Seller premises (Fee/Charges to be borne by the BUYER): Before

dispatch, the goods will be inspected by Buyer / Consignee or their Authorized Representative or by Nominated External Inspection Agency (independently or jointly with Buyer or Consignee as decided by the Buyer) at Seller premises (or at designated place for inspection as declared / communicated by the seller) for their compliance to the contract specifications. Fee/Charges taken by the External inspection Agency and any external laboratories testing charges shall be borne by the Buyer. For in-house testing, the Sellers will provide necessary facilities free of cost. Seller shall notify the Buyer through e-mail about readiness of goods for pre-dispatch inspection and Buyer will notify the Seller about the Authorized Representative/ Nominated External Inspection Agency and the date for testing. The goods would be dispatched to consignee only after clearance in pre-dispatch inspection. Consignee's right of rejection as per GTC in respect of the goods finally received at his location shall in no way be limited or waived by reason of the goods having previously been inspected, tested and passed by Buyer/ Consignee or its Nominated External Inspection Agency prior to the goods' shipment. While bidding, the sellers should take into account 7 days for inspection from the date of email offering the goods for inspection. Any delay in inspection beyond 7 days shall be on the part of the buyer and shall be regularised without Liquidated Damages.

When there is requirement of submission the advance sample, the seller shall inform the buyer promptly through emails about the date of submission of sample to the buyer nominated Inspection agency.

23. Certificates

Bidder's offer is liable to be rejected if they don't upload any of the certificates / documents sought in the Bid document, ATC and Corrigendum if any.

24. Certificates

Material Test Certificate Should Be Sent Along with The Supply. The Material Will Be Checked by Buyer's Lab & the Results of the Lab will be the Sole Criteria for Acceptance of the Item.

25. Certificates

The bidder is required to upload, along with the bid, all relevant certificates such as BIS licence, type test certificate, approval certificates and other certificates as prescribed in the Product Specification given in the bid document.

26. Warranty

Warranty period of the supplied products shall be as given in specifications from the date of final acceptance of goods or after completion of installation, commissioning & testing of goods (if included in the scope of supply), at consignee location. OEM Warranty certificates must be submitted by Successful Bidder at the time of delivery of Goods. The seller should guarantee the rectification of goods in case of any break down during the guarantee period. Seller should have well established Installation, Commissioning, Training, Troubleshooting and Maintenance Service group in INDIA for attending the after sales service. Details of Service Centres near consignee destinations are to be uploaded along with the bid.

27. Warranty

Successful bidder will have to ensure that adequate number of dedicated technical service personals / engineers are designated / deployed for attending to the Service Request in a time bound manner and for ensuring Timely Servicing / rectification of defects during warranty period, as per Service level agreement indicated in the relevant clause of the bid.

28. Warranty

Timely Servicing / rectification of defects during warranty period: After having been notified of the defects / service requirement during warranty period, Seller has to complete the required Service / Rectification within 3 days time limit. If the Seller fails to complete service / rectification with defined time limit, a penalty of 0.5% of Unit Price of the product shall be charged as penalty for each week of delay from the seller. Seller can deposit the penalty with the Buyer directly else the Buyer shall have a right to recover all such penalty amount from the Performance Security (PBG). Cumulative Penalty cannot exceed more than 10% of the total contract value after which the Buyer shall have the right to get the service / rectification done from alternate sources at the risk and cost of the Seller besides forfeiture of PBG. Seller shall be liable to re-imburse the cost of such service / rectification to the Buyer.

29. **Financial Criteria**

NET WORTH: Net Worth of the OEM should be positive as per the last audited financial statement.

30. **Buyer Added Bid Specific ATC**

Buyer Added text based ATC clauses

DOCUMENTS SATISFYING ELIGIBILITY CRITERIA

1. **DULY SIGNED AND STAMPED TENDER TERMS AS PER ANNEXURE II. IF ANY DEVIATION, PLEASE INDICATE SEPARATELY**
2. **DULY FILLED AND SIGNED COMMERCIAL TERM FORMAT AS PER ANNEXURE III-A, B, C, D**
3. **DULY FILLED AND SIGNED BID SECURITY DECLARATION & CLAUSE COMPLIANCE AS PER ANNEXURE -IV, V**
4. **PARTY HAS TO SUBMIT THE DRAWINGS & QAP FOR APPROVAL PRIOR TO MANUFACTURE**
5. **MTC AND GUARANTEE CERTIFICATES SHOULD BE PROVIDED ALONG WITH SUPPLY.**
6. **THE ITEMS ARE REQUIRED FOR ANNUAL SHUTDOWN 2023. HENCE PARTY HAS TO STRICTLY ADHERE TO THE DELIVERY PERIOD**
7. **DETAILED TECHNICAL SPECIFICATION OR CATALOGUE OF OFFERED PRODUCT SHOULD BE SUBMITTED ALONG WITH TECHNICAL BID**
8. **PARTY SHOULD PROVIDE 3 SET OF DRAWINGS IN HARD COPIES AND 1 SET OF DRAWING IN SOFT COPIES ALONG WITH THE SUPPLY.**
9. **THIRD PARTY INSPECTION : PLEASE NOTE THAT THIRD PARTY INSPECTION WILL BE APPLICABLE IN THIS PROCUREMENT. THIRD PARTY INSPECTION IS REQUIRED FOR 100% QUANTITY. OUR APPROVED THIRD PARTY AND THEIR DETAILS ARE AS UNDER.**

**M/S. BUREAU VERITAS (INDIA) PVT. LTD,
JOMER SYMPHONY, D/NO. 48/1744C39
UNIT 5, 6TH FLOOR, PONNURUNNI NORTH
VYTTILA P.O, KERALA - 682019.**

CONTACT PERSONS

MR. PETER PRAVEEN, EXECUTIVE

PHONE : [+91 9895111743/53](tel:+919895111743)

MOB : [+91 9895005639](tel:+919895005639),

E MAIL : PETER.PRAVEEN@BUREAUVERITAS.COM

MATERIALS WILL HAVE TO BE INSPECTED AT THE VENDOR'S WORKS PRIOR TO DESPATCH AND SHALL BE DESPATCHED ONLY AFTER THE INSPECTION & APPROVAL BY THE TPI. HOWEVER THE INSPECTION CHARGES TO THE THIRD PARTY SHALL BE BORNE BY HOCL AS PER HOCL'S AGREEMENT WITH THE THIRD PARTY. HOWEVER WHATEVER COST INCURRING FOR INSPECTION OF MATERIAL (LIKE NDT ETC.) SHOULD BE BORNE BY THE SUPPLIER. HENCE AS PER THE GEM TENDER TERMS THE RATE QUOTED SHALL BE ALL INCLUSIVE

31. Buyer Added Bid Specific ATC

Buyer uploaded ATC document [Click here to view the file.](#)

Disclaimer/अस्वीकरण

The additional terms and conditions have been incorporated by the Buyer after approval of the Competent Authority in Buyer Organization, whereby Buyer organization is solely responsible for the impact of these clauses on the bidding process, its outcome, and consequences thereof including any eccentricity / restriction arising in the bidding process due to these ATCs and due to modification of technical specifications and / or terms and conditions governing the bid. Any clause(s) incorporated by the Buyer regarding following shall be treated as null and void and would not be considered as part of bid:-

1. Definition of Class I and Class II suppliers in the bid not in line with the extant Order / Office Memorandum issued by DPIIT in this regard.
2. Seeking EMD submission from bidder(s), including via Additional Terms & Conditions, in contravention to exemption provided to such sellers under GeM GTC.
3. Publishing Custom / BOQ bids for items for which regular GeM categories are available without any Category item bunched with it.
4. Creating BoQ bid for single item.
5. Mentioning specific Brand or Make or Model or Manufacturer or Dealer name.
6. Mandating submission of documents in physical form as a pre-requisite to qualify bidders.
7. Floating / creation of work contracts as Custom Bids in Services.
8. Seeking sample with bid or approval of samples during bid evaluation process.
9. Mandating foreign / international certifications even in case of existence of Indian Standards without specifying equivalent Indian Certification / standards.
10. Seeking experience from specific organization / department / institute only or from foreign / export experience.
11. Creating bid for items from irrelevant categories.
12. Incorporating any clause against the MSME policy and Preference to Make in India Policy.
13. Reference of conditions published on any external site or reference to external documents/clauses.
14. Asking for any Tender fee / Bid Participation fee / Auction fee in case of Bids / Forward Auction, as the case may be.

Further, if any seller has any objection/grievance against these additional clauses or otherwise on any aspect of this bid, they can raise their representation against the same by using the Representation window provided in the bid details field in Seller dashboard after logging in as a seller within 4 days of bid publication on GeM. Buyer is duty bound to reply to all such representations and would not be allowed to open bids if he fails to reply to such representations.

[This Bid is also governed by the General Terms and Conditions/ यह बिड सामान्य शर्तों के अंतर्गत भी शासित है](#)

In terms of GeM GTC clause 26 regarding Restrictions on procurement from a bidder of a country which shares a land border with India, any bidder from a country which shares a land border with India will be eligible to bid in this tender only if the bidder is registered with the Competent Authority. While participating in bid, Bidder has to undertake compliance of this and any false declaration and non-compliance of this would be a ground for immediate termination of the contract and further legal action in accordance with the laws./जेम की सामान्य शर्तों के खंड 26 के संदर्भ में भारत के साथ भूमि सीमा साझा करने वाले देश के बिडर से खरीद पर प्रतिबंध के संबंध में भारत के साथ भूमि सीमा साझा करने वाले देश का कोई भी बिडर इस निविदा में बिड देने के लिए तभी पात्र होगा जब वह बिड देने वाला सक्षम प्राधिकारी के पास पंजीकृत हो। बिड में भाग लेते समय बिडर को इसका अनुपालन करना होगा और कोई भी गलत घोषणा किए जाने व इसका अनुपालन न करने पर अनुबंध को तत्काल समाप्त करने और कानून के अनुसार आगे की कानूनी कार्रवाई का आधार होगा।

---Thank You/धन्यवाद---



HINDUSTAN ORGANIC CHEMICALS LIMITED
(A GOVERNMENT OF INDIA ENTERPRISE)
AMBALAMUGAL, ERNAKULAM DISTRICT, PIN – 682 302
PHONE: (0484) 2720911, FAX No. (0484) 2720893

Item Number	Item Description	Item Quantity	Unit of Measure
1	COMPLETE TRAY ASSEMBLY FOR C2003 DEPROPANISER COLUMN AS PER THE ATTACHED DRAWINGS AND SPECIFICATION DETAILS SINGLE PASS SIEVE TRAYS WITH STRAIGHT DOWNCOMERS AND TRAY FASTENERS QTY REQUIRED: 12 NOS i.e TRAY NO.S 1,3,5,6,7,8,9,10,11,12,13, & 14 MOC for Tray deck, downcomer- IS2062 Gr A Column ID – 968 mm Column Manway ID – 476mm Column Design pressure – 21 kg/cm ² Column Design temperature - 190°C Volume – 20.5 m ³ Ref. Drawings 1) 9179-307-sheet 9 2) SE-UHEL-001-sheet 1 of 3 3) SE-UHEL-001-sheet 3 of 3 4)Drg.No: UHE-6288/A	12	NOS
2	"COMPLETE TRAY ASSEMBLY FOR C2003 DEPROPANISER COLUMN AS PER THE ATTACHED DRAWINGS AND SPECIFICATION DETAILS" SINGLE PASS SIEVE TRAYS WITH STRAIGHT DOWNCOMERS AND TRAY FASTENERS QTY REQUIRED: 3 NOS i.e TRAY NO.S 16,18, & 19) MOC for Tray deck, downcomer- IS2062 Gr A Column ID – 968 mm Column Manway ID – 476mm Column Design pressure – 21 kg/cm ² Column Design temperature - 190°C Volume – 20.5 m ³ Ref. Drawings 1) 9179-307-sheet 10 2) SE-UHEL-001-sheet 2 of 3 3) SE-UHEL-001-sheet 3 of 3 4)Drg.No: UHE-6288/A	3	SET

3	"COMPLETE TRAY ASSEMBLY FOR C2003 DEPROPANISER COLUMN AS PER THE ATTACHED DRAWINGS AND SPECIFICATION DETAILS" SINGLE PASS SIEVE TRAYS WITH DOWNCOMER, TRAP AND COLLECTOR, AND TRAY FASTENERS QTY REQUIRED: 1 NO (FOR TRAY NO. 20) MOC for Tray deck, downcomer- IS2062 Gr A Column ID – 968 mm Column Manway ID – 476mm Column Design pressure – 21 kg/cm2g Column Design temperature - 190°C Volume – 20.5 m3 Ref. Drawings 1) 9179-307-sheet 10, 11 & 12 2) SE-UHEL-001-sheet 2 of 3 3) SE-UHEL-001-sheet 3 of 3 4)Drg.No: UHE-6288/A	1	SET
---	--	---	-----

NOTE:

- **PARTY HAS TO SUBMIT THE DRAWINGS & QAP FOR APPROVAL PRIOR TO MANUFACTURE**
- **MTC, GUARANTEE CERTIFICATES & TPI CERTIFICATES SHOULD BE PROVIDED ALONG WITH SUPPLY.**
- **THE ITEMS ARE REQUIRED FOR ANNUAL SHUTDOWN 2023. HENCE PARTY HAS TO STRICTLY ADHERE TO THE DELIVERY PERIOD**
- **DETAILED TECHNICAL SPECIFICATION OR CATALOGUE OF OFFERED PRODUCT SHOULD BE SUBMITTED ALONG WITH TECHNICAL BID**
- **PARTY SHOULD PROVIDE 3 SET OF DRAWINGS IN HARD COPIES AND 1 SET OF DRAWING IN SOFT COPIES ALONG WITH THE SUPPLY.**
- **THIRD PARTY INSPECTION : PLEASE NOTE THAT THIRD PARTY INSPECTION WILL BE APPLICABLE IN THIS PROCUREMENT. THIRD PARTY INSPECTION IS REQUIRED FOR 100% QUANTITY. OUR APPROVED THIRD PARTY AND THEIR DETAILS ARE AS UNDER.**

**M/S. BUREAU VERITAS (INDIA) PVT. LTD,
JOMER SYMPHONY, D/NO. 48/1744C39
UNIT 5, 6TH FLOOR, PONNURUNNI NORTH
VYTTILA P.O, KERALA – 682019.**

CONTACT PERSONS

- 1) MR. PETER PRAVEEN, EXECUTIVE
PHONE : +91 9895111743/53
MOB : +91 9895005639,
E MAIL : PETER.PRAVEEN@BUREAUVERITAS.COM

MATERIALS WILL HAVE TO BE INSPECTED AT THE VENDOR'S WORKS PRIOR TO DESPATCH AND SHALL BE DESPATCHED ONLY AFTER THE INSPECTION & APPROVAL BY THE TPI. HOWEVER THE INSPECTION CHARGES TO THE THIRD PARTY SHALL BE BORNE BY HOCL AS PER HOCL'S AGREEMENT WITH THE THIRD PARTY. HOWEVER WHATEVER COST INCURRING FOR INSPECTION OF MATERIAL (LIKE NDT ETC.) SHOULD BE BORNE BY THE SUPPLIER. HENCE AS PER THE GEM TENDER TERMS THE RATE QUOTED SHALL BE ALL INCLUSIVE

DATASHEET IS AS GIVEN BELOW:

THE FOLLOWING GENERAL NOTES APPLY TO ALL ITEMS LISTED ON INDIVIDUAL SPECIFICATION SHEET:

- A. All items shall comply with the requirements, terms and conditions of UOP Specification 3-18- /.
- B. All trays are numbered from top (# 1) to bottom.
- C. Material abbreviations: C.S. = carbon steel, 410 = 12% chromium alloy, 304 = 18-8 stainless steel.
- D. If there is agreement by UOP for purchase of proprietary valve type trays in lieu of sieve trays, such trays shall be designed in accordance with the tray data on individual specification sheet and accompanying sieve tray layout. Downcomer dimensions as shown for sieve tray layout shall be followed as closely as possible. Minor deviations to adjust for proprietary cap arrangement will be accepted. All valve parts shall be Type 410 chromium alloy for carbon steel trays and chromium alloy trays. Valve parts for higher alloy trays shall match the tray metallurgy.
- E. System of measurement is metric; all dimensions are to be in millimeters except as noted.
- F. For columns where the specified I.D. is indicated to be minimum (Min.), adjustments in tray dimensions to accommodate the final I.D. selected shall be to the chord heights of side downcomers which are also indicated as minimum (Min.). For consistency with this dimensional adjustment, the I.D. of the top (or suitable) manway of the column must be equal to or greater than the largest downcomer chord height or width plus 100 mm, to avoid tray joints under downcomers.

THE FOLLOWING NOTES APPLY ONLY WHEN LISTED FOR INDIVIDUAL ITEM OF SPECIFICATION SHEET:

1. One pass. 2. Two pass, center downcomer. 2X. Two pass, side downcomer.
3. Three pass. 4. Four pass, intermediate downcomer. 4X. Four pass, side and center downcomers.
5. Support rings, downcomer and upcomer bars, and other parts welded to vessel shall match the metallurgy of the vessel shell or lining, whichever is the higher alloy.
6. Downcomer(s) shall conform to transition cone of vessel, contractor to furnish cone details.
7. Tray(s) shall be liquid tight by seal welding, except at manway(s) use gasketing.
8. Tray(s) including downcomer(s) shall be liquid tight by seal welding, . Manway(s) shall be gasketed.
9. Weirs shall be level. Use adjustable weirs which are sealed against leakage.
10. Do not provide drain holes. Tray(s) shall be liquid tight.
11. Stiffeners and support members transverse to the liquid flow direction shall not exceed 2 inches in depth and shall not be located above upcomers, or within a lateral distance from upcomers equal to one tray space.
12. Trays shall be assembled on rods and spacers or arranged in cartridges with trap attached to downcomer of bottom tray.
13. Trap shall be located in transition cone of vessel and properly feed the tray or accumulator below.
14. All tray assemblies shall be designed for installation and removal from top and bottom.
15. Each tray shall have froth initiator(s) in accordance with UOP Std. Dwg. No. 3-130-.
16. Trap(s) below tray shall be baffled, or alternately tray shall have vapor tunnel(s) in downcomers to allow vapor flow across tray.

VESSEL TRAYS

NUMBER 9179 - 307 - 0 REVISION

SHEET 3 OF

BY APP'D

DATE

NAME OF VESSEL *DEPROPANIZER*

ITEM *C-2003*

ITEM NO.	QUAN. (ASSEM.)	I.D. OF VESSEL	MATERIAL	DESCRIPTION	DWG. NO. OR SHEET NO.	TRAY NOS.	NOTES
1	14	950 (MIN.)	C.S.	SIEVE TRAYS	9	1-14	1
2	5	950 (MIN.)	C.S.	SIEVE TRAYS	10	15-19	1
3	1	950 (MIN.)	C.S.	SIEVE TRAY	10	20	1, 6
4	1	-	C.S.	TRAP	11	BELOW 20	13
5	1	-	C.S.	COLLECTOR	12	BELOW 20	7, 19, 24

For notes 1 thru 16 see sheet 2.

THE FOLLOWING NOTES APPLY ONLY WHEN SPECIFIED ABOVE.

- Bubble caps shall be in accordance with UOP Std. Dwg. No. _____ Type No. _____.
- Bolts and nuts for manway(s) shall be Type 304 (ASTM A193 Grade B8 for bolts and A194 Grade 8 for nuts), Type 410 (ASTM A193 Grade B6 or B6X for bolts and A194 Grade 6 for nuts).
- Asbestos, ~~asbestos gaskets~~ gasketing, shall be used as required for proper design and installation of tray(s) manway.
- Each tray shall have a total of _____ diameter holes on approximately _____ square, equilateral triangular pitch.
- Each tray shall be designed for an upward pressure differential of _____.
- See sketch below.
- Drawoff well(s) on tray No. _____ shall be _____ mm deep and a minimum of _____ mm wide and extend under entire downcomer area.
- COLLECTOR SHALL BE LOCATED IN TRANSITION CONE OF VESSEL.

TRAY DATA:

MAXIMUM ALLOWABLE OVERALL PRESSURE DROP FOR VESSEL *0.21 KG/CM²*
 SERVICE *UOP CATALYTIC CONDENSATION PROCESS* FOAMING TENDENCY - *LOW*

FLUID DESCRIPTION *H₂BN*

TRAY SPACING, mm *600 (TYP.) EXCEPT; 800 = 10-11; 900 = 14-15, 20 TO COLLECTOR.*

LOADING FOR TRAYS	1-14	15-20
OPERATING PRESS., KG/CM ² (G)	18.10	18.20
OPERATING TEMP., °C	54	132
STRUCTURAL DESIGN TEMP. °C	190	190
VAPOR RATE, Kg/h	12070	4516
VAPOR DENSITY, Kg/m ³	42.3	36.2
LIQUID RATE, Kg/h	11172	34330
LIQUID DENSITY Kg/m ³	444	668
SURFACE TENSION, DYNES/CM.	3.5	10.7

ALL SECTIONS SHALL PASS THROUGH AN *18"* I.D. VESSEL MANWAY.

400 HEAT EXCHANGERS
 500 PUMPS & COMPRESSORS
 INSTRUMENTS

VESSEL TRAYS

NUMBER REVISION

9179-307- 0

SHEET 9 OF

BY APP'D

DATE

NAME OF VESSEL *DEPROPANIZER*

ITEM *C-2003*

ONE-PASS SIEVE TRAYS (STRAIGHT DOWNCOMERS)

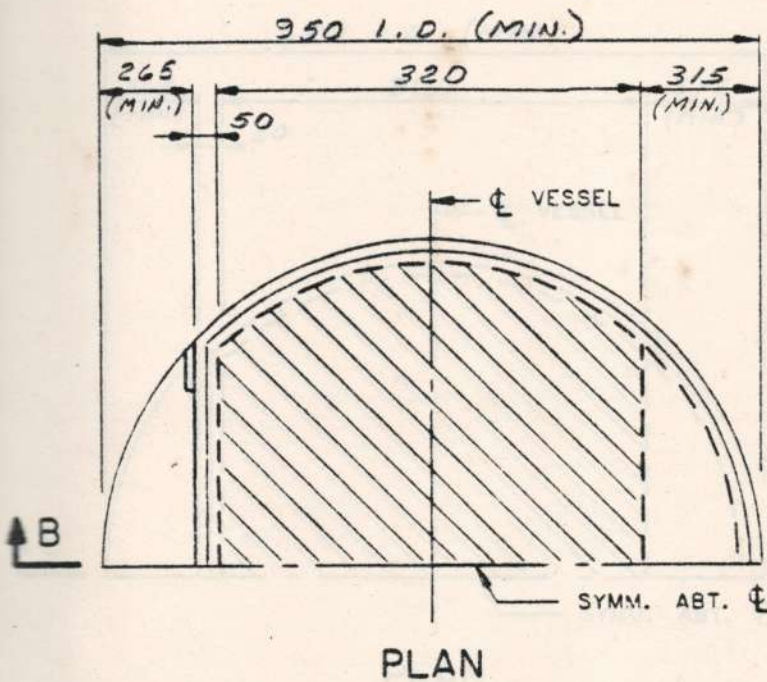

180 TOTAL 1/8 DIAMETER UNOBSTRUCTED HOLES PER TRAY EVENLY DISTRIBUTED ON SQUARE OR EQUILATERAL TRIANGULAR PITCH THROUGHOUT SHADED AREA

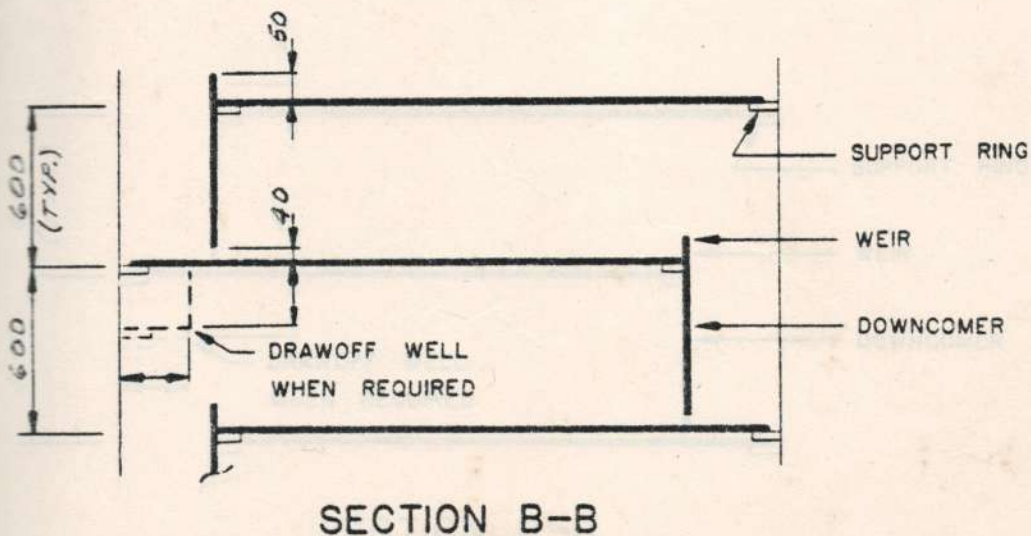

400 HEAT EXCHANGERS
500 PUMPS & COMPRESSORS
INSTUMENTS

VESSEL TRAYS

NUMBER REVISION

9179 -307- 0

SHEET 10 OF

BY APP'D

DATE

NAME OF VESSEL DEPROPANIZER

ITEM C-2003

ONE-PASS SIEVE TRAYS
(STRAIGHT DOWNCOMERS)

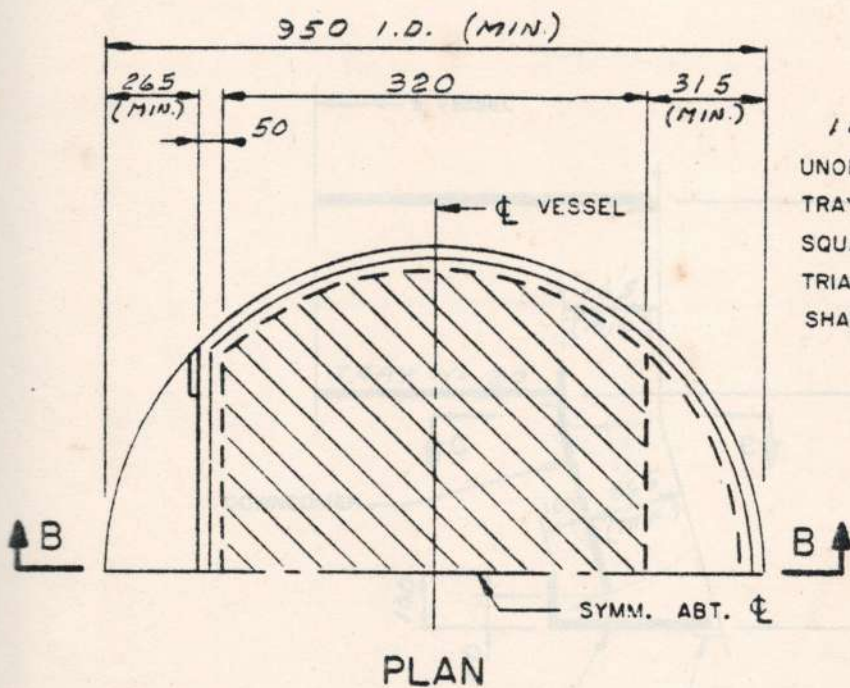

100 TOTAL 1/8 DIAMETER UNOBSTRUCTED HOLES PER TRAY EVENLY DISTRIBUTED ON SQUARE OR EQUILATERAL TRIANGULAR PITCH THROUGHOUT SHADED AREA

PLAN

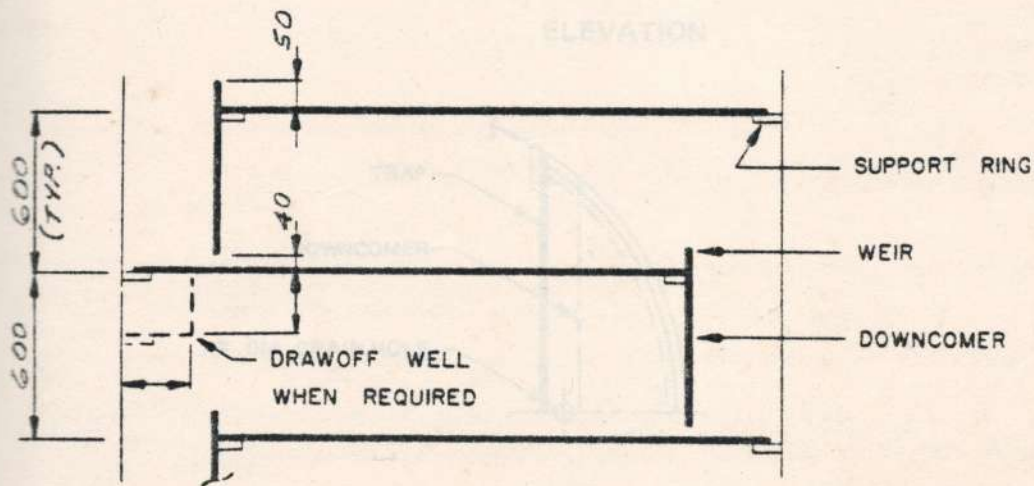

SECTION B-B

400 HEAT EXCHANGERS
500 PUMPS & COMPRESSORS
IN INSTRUMENTS

VESSEL TRAYS

NUMBER 9179 - 307 - 0 REVISION

SHEET 11 OF

BY APP'D

DATE

NAME OF VESSEL DEPROPANIZER

ITEM C-2003

TRAPS
(ONE-PASS OR TWO-PASS SIDE DOWNCOMER SIEVE TRAY IN VESSEL CONE)

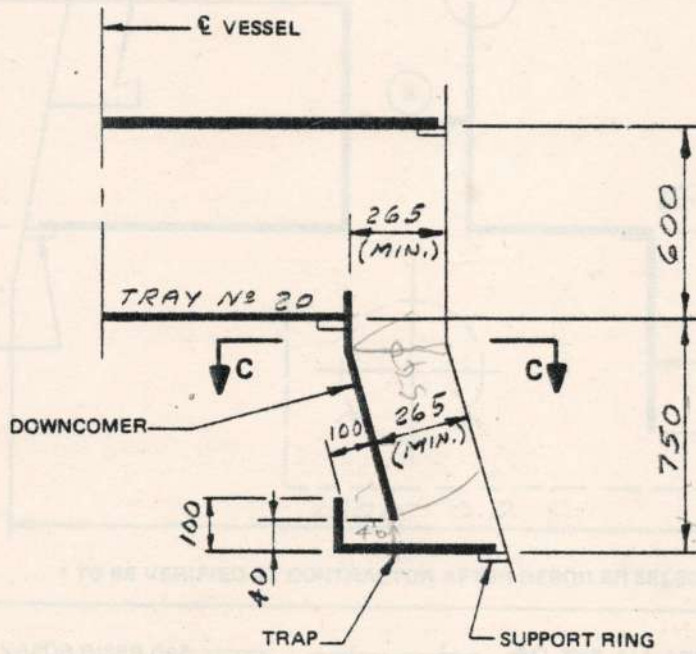

ELEVATION

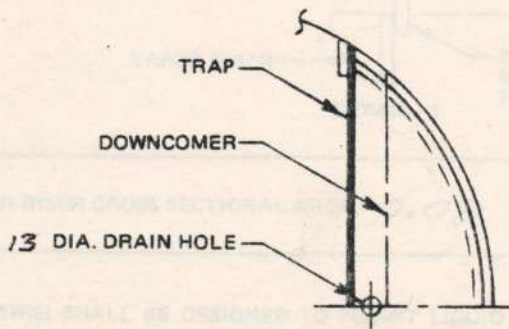

1. VAPOR FLOW SHALL BE DESIGNED TO BE UNIFORM ACROSS THE COLLECTOR TRAY AND WHERE PRACTICAL SHALL PERMIT TURBULENCE ACTION. SHAPE AND NUMBER SHALL BE DETERMINED BY TRAY SUPPLIER.
2. COLLECTOR TRAY SHALL BE LIQUID TIGHT BY SEAL WELDING EXCEPT MANWAY SHALL BE BOLTED AND GASKETED TO NOT PROVIDE DRAINAGE.

400 HEAT EXCHANGERS
500 PUMPS & COMPRESSORS
INSTRUMENTS

VESSEL TRAYS
COLLECTOR TRAY

NUMBER 9179 - 307 - 0 REVISION

SHEET 12 OF

BY APP'D

DATE

NAME OF VESSEL DEPROPANIZER

ITEM C-2003

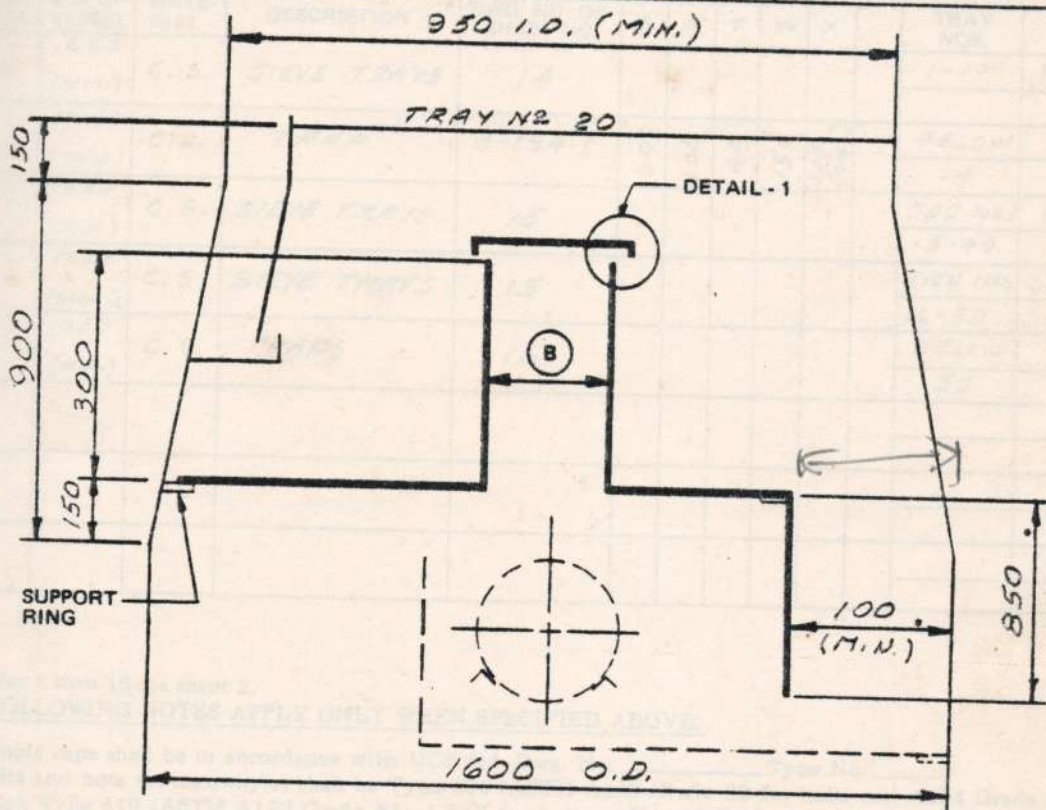

* TO BE VERIFIED BY CONTRACTOR AFTER REBOILER SELECTION

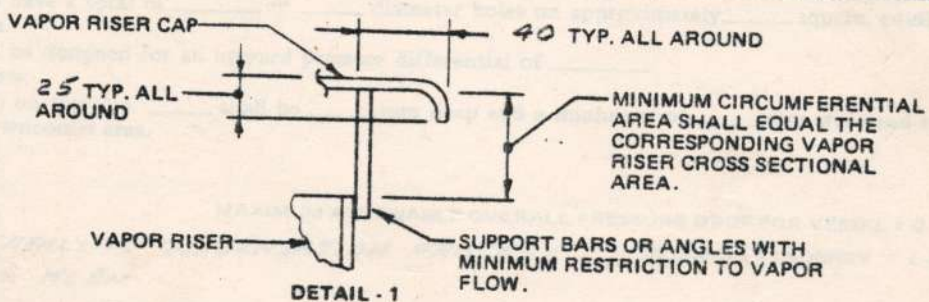

(B) TOTAL VAPOR RISER CROSS SECTIONAL AREA = 0.08 SQUARE METERS

NOTES:

- VAPOR RISER(S) SHALL BE DESIGNED TO PERMIT LIQUID EQUALIZATION ACROSS THE COLLECTOR TRAY AND WHERE PRACTICAL SHALL PERMIT PERSONNEL ACCESS. SHAPE AND NUMBER SHALL BE DETERMINED BY TRAY SUPPLIER.
- COLLECTOR TRAY SHALL BE LIQUID TIGHT BY SEAL WELDING, EXCEPT MANWAY SHALL BE BOLTED AND GASKETED. DO NOT PROVIDE DRAIN HOLES.

400 HEAT EXCHANGERS
500 PUMPS & COMPRESSORS
INSTRUMENTS

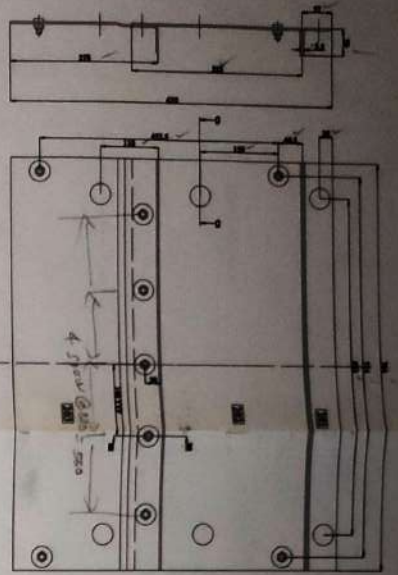

DETAIL OF DOWNCOMER FOR TRAYS 1 TO 9, 11 TO 13 AND 15 TO 19

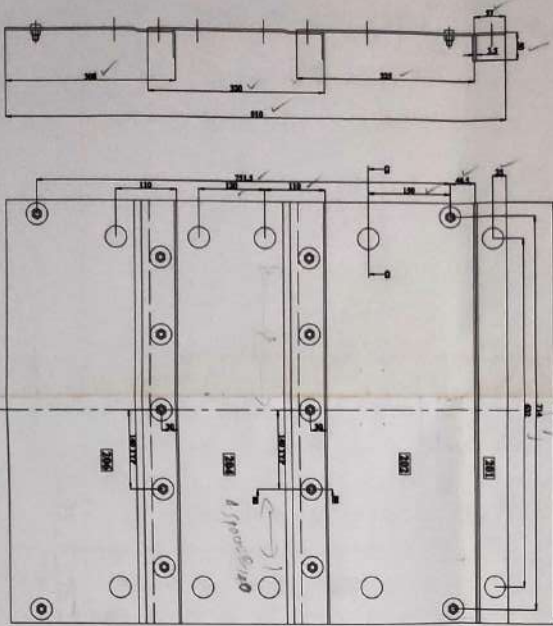

DETAIL OF DOWNCOMER FOR TRAY 14

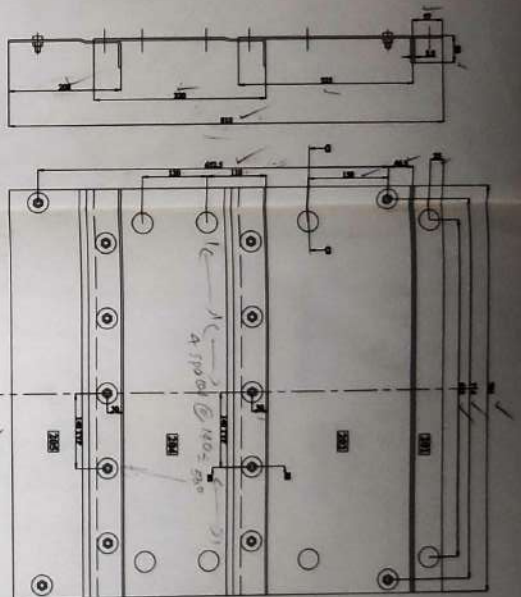

DETAIL OF DOWNCOMER FOR TRAY 10

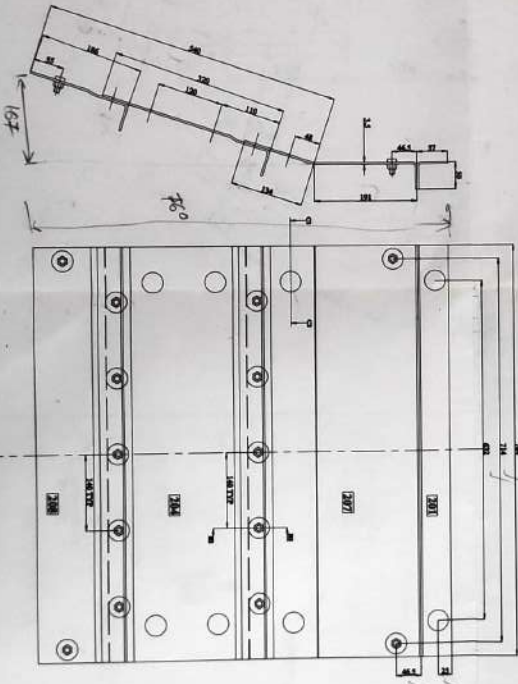

DETAIL OF DOWNCOMER FOR TRAY 20

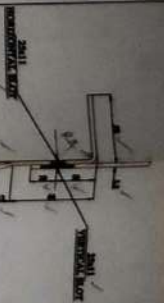

SECTION B-B

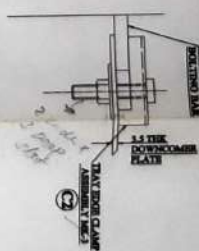

SECTION C-C

GENERAL NOTE:
 1. ALL DIMENSIONS ARE IN MM UNLESS STATED.
 2. FOR TRAY DETAILS SEE THE DRAWINGS NO. SE-UHEB-001 SHEET 1 OF 3 & SHEET 2 OF 3.
 3. ALL PARTS ARE DESIGNED TO PASS THROUGH 478 ID OF MANHOLE.

GENERAL TRAY INFORMATION

COLUMN ID	= 968
TRAY REF RADIUS	= 469.5
CLAMP REF RADIUS	= 429
SUPPORT RING SIZE	= 40 x 10
RADIAL SLOT SIZE	= 25 x 11
OTHER SLOTS SIZE	= 25 x 11
BOLTING BAR	= 10 THK

ITEM NO.	DESCRIPTION	QTY	MATERIAL	UNIT
1	TRAY DECK CLAMP 10x3	2	ASTM A 307 SS 4108	(4) INCH
2	20MM WADERS	2	ASTM A 307 SS 4108	Ø 75 INCH
3	ASTM A 156 Ø 8	1	ASTM A 156 Ø 8	Ø 8 INCH
4	ASTM A 156 Ø 8	1	ASTM A 156 Ø 8	Ø 8 INCH
5	ASTM A 156 Ø 8	1	ASTM A 156 Ø 8	Ø 8 INCH
6	ASTM A 156 Ø 8	1	ASTM A 156 Ø 8	Ø 8 INCH
7	ASTM A 156 Ø 8	1	ASTM A 156 Ø 8	Ø 8 INCH
8	ASTM A 156 Ø 8	1	ASTM A 156 Ø 8	Ø 8 INCH
9	ASTM A 156 Ø 8	1	ASTM A 156 Ø 8	Ø 8 INCH
10	ASTM A 156 Ø 8	1	ASTM A 156 Ø 8	Ø 8 INCH
11	ASTM A 156 Ø 8	1	ASTM A 156 Ø 8	Ø 8 INCH
12	ASTM A 156 Ø 8	1	ASTM A 156 Ø 8	Ø 8 INCH
13	ASTM A 156 Ø 8	1	ASTM A 156 Ø 8	Ø 8 INCH
14	ASTM A 156 Ø 8	1	ASTM A 156 Ø 8	Ø 8 INCH
15	ASTM A 156 Ø 8	1	ASTM A 156 Ø 8	Ø 8 INCH
16	ASTM A 156 Ø 8	1	ASTM A 156 Ø 8	Ø 8 INCH
17	ASTM A 156 Ø 8	1	ASTM A 156 Ø 8	Ø 8 INCH
18	ASTM A 156 Ø 8	1	ASTM A 156 Ø 8	Ø 8 INCH
19	ASTM A 156 Ø 8	1	ASTM A 156 Ø 8	Ø 8 INCH
20	ASTM A 156 Ø 8	1	ASTM A 156 Ø 8	Ø 8 INCH
21	ASTM A 156 Ø 8	1	ASTM A 156 Ø 8	Ø 8 INCH
22	ASTM A 156 Ø 8	1	ASTM A 156 Ø 8	Ø 8 INCH
23	ASTM A 156 Ø 8	1	ASTM A 156 Ø 8	Ø 8 INCH
24	ASTM A 156 Ø 8	1	ASTM A 156 Ø 8	Ø 8 INCH
25	ASTM A 156 Ø 8	1	ASTM A 156 Ø 8	Ø 8 INCH
26	ASTM A 156 Ø 8	1	ASTM A 156 Ø 8	Ø 8 INCH
27	ASTM A 156 Ø 8	1	ASTM A 156 Ø 8	Ø 8 INCH
28	ASTM A 156 Ø 8	1	ASTM A 156 Ø 8	Ø 8 INCH
29	ASTM A 156 Ø 8	1	ASTM A 156 Ø 8	Ø 8 INCH
30	ASTM A 156 Ø 8	1	ASTM A 156 Ø 8	Ø 8 INCH
31	ASTM A 156 Ø 8	1	ASTM A 156 Ø 8	Ø 8 INCH
32	ASTM A 156 Ø 8	1	ASTM A 156 Ø 8	Ø 8 INCH
33	ASTM A 156 Ø 8	1	ASTM A 156 Ø 8	Ø 8 INCH
34	ASTM A 156 Ø 8	1	ASTM A 156 Ø 8	Ø 8 INCH
35	ASTM A 156 Ø 8	1	ASTM A 156 Ø 8	Ø 8 INCH
36	ASTM A 156 Ø 8	1	ASTM A 156 Ø 8	Ø 8 INCH
37	ASTM A 156 Ø 8	1	ASTM A 156 Ø 8	Ø 8 INCH
38	ASTM A 156 Ø 8	1	ASTM A 156 Ø 8	Ø 8 INCH
39	ASTM A 156 Ø 8	1	ASTM A 156 Ø 8	Ø 8 INCH
40	ASTM A 156 Ø 8	1	ASTM A 156 Ø 8	Ø 8 INCH
41	ASTM A 156 Ø 8	1	ASTM A 156 Ø 8	Ø 8 INCH
42	ASTM A 156 Ø 8	1	ASTM A 156 Ø 8	Ø 8 INCH
43	ASTM A 156 Ø 8	1	ASTM A 156 Ø 8	Ø 8 INCH
44	ASTM A 156 Ø 8	1	ASTM A 156 Ø 8	Ø 8 INCH
45	ASTM A 156 Ø 8	1	ASTM A 156 Ø 8	Ø 8 INCH
46	ASTM A 156 Ø 8	1	ASTM A 156 Ø 8	Ø 8 INCH
47	ASTM A 156 Ø 8	1	ASTM A 156 Ø 8	Ø 8 INCH
48	ASTM A 156 Ø 8	1	ASTM A 156 Ø 8	Ø 8 INCH
49	ASTM A 156 Ø 8	1	ASTM A 156 Ø 8	Ø 8 INCH
50	ASTM A 156 Ø 8	1	ASTM A 156 Ø 8	Ø 8 INCH
51	ASTM A 156 Ø 8	1	ASTM A 156 Ø 8	Ø 8 INCH
52	ASTM A 156 Ø 8	1	ASTM A 156 Ø 8	Ø 8 INCH
53	ASTM A 156 Ø 8	1	ASTM A 156 Ø 8	Ø 8 INCH
54	ASTM A 156 Ø 8	1	ASTM A 156 Ø 8	Ø 8 INCH
55	ASTM A 156 Ø 8	1	ASTM A 156 Ø 8	Ø 8 INCH
56	ASTM A 156 Ø 8	1	ASTM A 156 Ø 8	Ø 8 INCH
57	ASTM A 156 Ø 8	1	ASTM A 156 Ø 8	Ø 8 INCH
58	ASTM A 156 Ø 8	1	ASTM A 156 Ø 8	Ø 8 INCH
59	ASTM A 156 Ø 8	1	ASTM A 156 Ø 8	Ø 8 INCH
60	ASTM A 156 Ø 8	1	ASTM A 156 Ø 8	Ø 8 INCH
61	ASTM A 156 Ø 8	1	ASTM A 156 Ø 8	Ø 8 INCH
62	ASTM A 156 Ø 8	1	ASTM A 156 Ø 8	Ø 8 INCH
63	ASTM A 156 Ø 8	1	ASTM A 156 Ø 8	Ø 8 INCH
64	ASTM A 156 Ø 8	1	ASTM A 156 Ø 8	Ø 8 INCH
65	ASTM A 156 Ø 8	1	ASTM A 156 Ø 8	Ø 8 INCH
66	ASTM A 156 Ø 8	1	ASTM A 156 Ø 8	Ø 8 INCH
67	ASTM A 156 Ø 8	1	ASTM A 156 Ø 8	Ø 8 INCH
68	ASTM A 156 Ø 8	1	ASTM A 156 Ø 8	Ø 8 INCH
69	ASTM A 156 Ø 8	1	ASTM A 156 Ø 8	Ø 8 INCH
70	ASTM A 156 Ø 8	1	ASTM A 156 Ø 8	Ø 8 INCH
71	ASTM A 156 Ø 8	1	ASTM A 156 Ø 8	Ø 8 INCH
72	ASTM A 156 Ø 8	1	ASTM A 156 Ø 8	Ø 8 INCH
73	ASTM A 156 Ø 8	1	ASTM A 156 Ø 8	Ø 8 INCH
74	ASTM A 156 Ø 8	1	ASTM A 156 Ø 8	Ø 8 INCH
75	ASTM A 156 Ø 8	1	ASTM A 156 Ø 8	Ø 8 INCH
76	ASTM A 156 Ø 8	1	ASTM A 156 Ø 8	Ø 8 INCH
77	ASTM A 156 Ø 8	1	ASTM A 156 Ø 8	Ø 8 INCH
78	ASTM A 156 Ø 8	1	ASTM A 156 Ø 8	Ø 8 INCH
79	ASTM A 156 Ø 8	1	ASTM A 156 Ø 8	Ø 8 INCH
80	ASTM A 156 Ø 8	1	ASTM A 156 Ø 8	Ø 8 INCH
81	ASTM A 156 Ø 8	1	ASTM A 156 Ø 8	Ø 8 INCH
82	ASTM A 156 Ø 8	1	ASTM A 156 Ø 8	Ø 8 INCH
83	ASTM A 156 Ø 8	1	ASTM A 156 Ø 8	Ø 8 INCH
84	ASTM A 156 Ø 8	1	ASTM A 156 Ø 8	Ø 8 INCH
85	ASTM A 156 Ø 8	1	ASTM A 156 Ø 8	Ø 8 INCH
86	ASTM A 156 Ø 8	1	ASTM A 156 Ø 8	Ø 8 INCH
87	ASTM A 156 Ø 8	1	ASTM A 156 Ø 8	Ø 8 INCH
88	ASTM A 156 Ø 8	1	ASTM A 156 Ø 8	Ø 8 INCH
89	ASTM A 156 Ø 8	1	ASTM A 156 Ø 8	Ø 8 INCH
90	ASTM A 156 Ø 8	1	ASTM A 156 Ø 8	Ø 8 INCH
91	ASTM A 156 Ø 8	1	ASTM A 156 Ø 8	Ø 8 INCH
92	ASTM A 156 Ø 8	1	ASTM A 156 Ø 8	Ø 8 INCH
93	ASTM A 156 Ø 8	1	ASTM A 156 Ø 8	Ø 8 INCH
94	ASTM A 156 Ø 8	1	ASTM A 156 Ø 8	Ø 8 INCH
95	ASTM A 156 Ø 8	1	ASTM A 156 Ø 8	Ø 8 INCH
96	ASTM A 156 Ø 8	1	ASTM A 156 Ø 8	Ø 8 INCH
97	ASTM A 156 Ø 8	1	ASTM A 156 Ø 8	Ø 8 INCH
98	ASTM A 156 Ø 8	1	ASTM A 156 Ø 8	Ø 8 INCH
99	ASTM A 156 Ø 8	1	ASTM A 156 Ø 8	Ø 8 INCH
100	ASTM A 156 Ø 8	1	ASTM A 156 Ø 8	Ø 8 INCH

REVISIONS

NO.	DATE	DESCRIPTION	BY	CHKD	APPR.
0	11/20/20	ISSUED FOR TRAYS 1 TO 20	BLANK	BLANK	BLANK

VENDOR DOCUMENT REVIEW

Z - FINAL A - ACCEPTED WITH COMMENTS

N - NOT ACCEPTABLE I - FOR INFORMATION

ENGINEER'S SIGN: _____ DATE: _____

DRG NO	SE-UHEB-001	DATE	11/21/20
SHEET	3 OF 3		
REF. DRG.	HCOI-007-2002 SHEET 2 OF 2		
EQPT NO	C-2003		
SCALE	P.O. NUMBER	REV NO	
	928798288	0	
			AT WASH

