

**बिड दस्तावेज़ / Bid Document**

बिड विवरण/Bid Details	
बिड बंद होने की तारीख/समय /Bid End Date/Time	16-04-2026 14:00:00
बिड खुलने की तारीख/समय /Bid Opening Date/Time	16-04-2026 14:30:00
बिड पेशकश वैधता (बंद होने की तारीख से)/Bid Offer Validity (From End Date)	90 (Days)
मंत्रालय/राज्य का नाम/Ministry/State Name	Ministry Of Chemicals And Fertilizers
विभाग का नाम/Department Name	Department Of Chemicals And Petrochemicals
संगठन का नाम/Organisation Name	Hindustan Organic Chemicals Limited
कार्यालय का नाम/Office Name	Ambalamugal,ernakulam
वस्तु श्रेणी /Item Category	Custom Bid for Services - INSTALLATION OF CABLE TRAY SYSTEM FOR POND MOTOR
समान श्रेणी/Similar Category	<ul style="list-style-type: none"> <li>• Electric Cabling Service</li> <li>• Operation and Maintenance Of Electrical Systems/Electrical Installations</li> <li>• Repair, Maintenance, and Installation of Plant/ Systems/Equipments (Version 2)</li> </ul>
अनुबंध अवधि /Contract Period	9 Month(s)
बिडर का न्यूनतम औसत वार्षिक टर्नओवर (3 वर्षों का) /Minimum Average Annual Turnover of the bidder (For 3 Years)	2 Lakh (s)
उन्हीं/समान सेवा के लिए अपेक्षित विगत अनुभव के वर्ष/Years of Past Experience Required for same/similar service	7 Year (s)
वर्षों के अनुभव एवं टर्नओवर से एमएसई को छूट प्राप्त है / MSE Relaxation for Years Of Experience and Turnover	Yes   Complete
स्टार्टअप के लिए अनुभव के वर्षों और टर्नओवर से छूट प्रदान की गई है /Startup Relaxation for Years of Experience and Turnover	No
विक्रेता से मांगे गए दस्तावेज़/Document required from seller	Experience Criteria,Bidder Turnover,Certificate (Requested in ATC),Additional Doc 1 (Requested in ATC) *In case any bidder is seeking exemption from Experience / Turnover Criteria, the supporting documents to prove his eligibility for exemption must be uploaded for evaluation by the buyer

**बिड विवरण/Bid Details**

क्या आप निविदाकारों द्वारा अपलोड किए गए दस्तावेजों को निविदा में भाग लेने वाले सभी निविदाकारों को दिखाना चाहते हैं? संदर्भ मेन् है/Do you want to show documents uploaded by bidders to all bidders participated in bid?	Yes (Documents submitted as part of a clarification or representation during the tender/bid process will also be displayed to other participated bidders after log in)
बिड लगाने की समय सीमा स्वतः नहीं बढ़ाने के लिए आवश्यक बिड की संख्या। / Minimum number of bids required to disable automatic bid extension	3
दिनों की संख्या, जिनके लिए बिड लगाने की समय-सीमा बढ़ाई जाएगी। / Number of days for which Bid would be auto-extended	7
ऑटो एक्सटेंशन अधिकतम कितनी बार किया जाना है। / Number of Auto Extension count	1
बिड से रिवर्स नीलामी सक्रिय किया/Bid to RA enabled	No
बिड का प्रकार/Type of Bid	Two Packet Bid
तकनीकी मूल्यांकन के दौरान तकनीकी स्पष्टीकरण हेतु अनुमत समय /Time allowed for Technical Clarifications during technical evaluation	2 Days
मूल्यांकन पद्धति/Evaluation Method	Total value wise evaluation
मूल्य दर्शाने वाला वित्तीय दस्तावेज ब्रेकअप आवश्यक है / Financial Document Indicating Price Breakup Required	Yes
मध्यस्थता खंड/Arbitration Clause	No
सुलह खंड/Mediation Clause	No

**ईएमडी विवरण/EMD Detail**

आवश्यकता/Required	No
-------------------	----

**ईपीबीजी विवरण /ePBG Detail**

आवश्यकता/Required	No
-------------------	----

बोली विभाजन लागू नहीं किया गया/ Bid splitting not applied.

**एमआईआई अनुपालन/MII Compliance**

एमआईआई अनुपालन/MII Compliance	Yes
-------------------------------	-----

## एमएसई खरीद वरीयता/MSE Purchase Preference

एमएसई खरीद वरीयता/MSE Purchase Preference	Yes
सूक्ष्म और लघु उद्यम मूल उपकरण निर्माताओं को खरीद में प्राथमिकता, यदि उनका मूल्य L1+X% तक की सीमा में हो / Purchase Preference to MSE OEMs available upto price within L1+X%	15

1. If the bidder is a Micro or Small Enterprise as per latest orders issued by Ministry of MSME, the bidder shall be relaxed from the eligibility criteria of "Experience Criteria" as defined above subject to meeting of quality and technical specifications. The bidder seeking Relaxation from Experience Criteria, shall upload the supporting documents to prove his eligibility for Relaxation.
2. If the bidder is a Micro or Small Enterprise (MSE) as per latest orders issued by Ministry of MSME, the bidder shall be relaxed from the eligibility criteria of "Bidder Turnover" as defined above subject to meeting of quality and technical specifications. If the bidder itself is MSE OEM of the offered products, it would be relaxed from the "OEM Average Turnover" criteria also subject to meeting of quality and technical specifications. The bidder seeking Relaxation from Turnover, shall upload the supporting documents to prove his eligibility for Relaxation.
3. The minimum average annual financial turnover of the bidder during the last three years, ending on 31st March of the previous financial year, should be as indicated above in the bid document. Documentary evidence in the form of certified Audited Balance Sheets of relevant periods or a certificate from the Chartered Accountant / Cost Accountant indicating the turnover details for the relevant period shall be uploaded with the bid. In case the date of constitution / incorporation of the bidder is less than 3-year-old, the average turnover in respect of the completed financial years after the date of constitution shall be taken into account for this criteria.
4. Years of Past Experience required: The bidder must have experience for number of years as indicated above in bid document (ending month of March prior to the bid opening) of providing similar type of services to any Central / State Govt Organization / PSU. Copies of relevant contracts / orders to be uploaded along with bid in support of having provided services during each of the Financial year.
5. Purchase preference to Micro and Small Enterprises (MSEs): Purchase preference will be given to MSEs as defined in Public Procurement Policy for Micro and Small Enterprises (MSEs) Order, 2012 dated 23.03.2012 issued by Ministry of Micro, Small and Medium Enterprises and its subsequent Orders/Notifications issued by concerned Ministry. If the bidder wants to avail the Purchase preference for services, the bidder must be the Service provider of the offered Service. Relevant documentary evidence in this regard shall be uploaded along with the bid in respect of the offered service. If L-1 is not an MSE and MSE Service Provider (s) has/have quoted price within L-1+ 15% of margin of purchase preference /price band as defined in the relevant policy, then 100% order quantity will be awarded to such MSE bidder subject to acceptance of L1 bid price. The buyers are advised to refer to the [OM No.1 4 2021 PPD dated 18.05.2023](#) for compliance of Concurrent application of Public Procurement Policy for Micro and Small Enterprises Order, 2012 and Public Procurement (Preference to Make in India) Order, 2017. Benefits of MSE will be allowed only if the credentials of the service provider are validated on-line in GeM profile as well as validated and approved by the Buyer after evaluation of submitted documents.
6. If L-1 is not an MSE and MSE Service Provider (s) has/have quoted price within L-1+ 15% of margin of purchase preference /price band as defined in the relevant policy, then 100% order quantity will be awarded to such MSE bidder subject to acceptance of L1 bid price.
7. Estimated Bid Value indicated above is being declared solely for the purpose of guidance on EMD amount and for determining the Eligibility Criteria related to Turn Over, Past Performance and Project / Past Experience etc. This has no relevance or bearing on the price to be quoted by the bidders and is also not going to have any impact on bid participation. Also this is not going to be used as a criteria in determining reasonableness of quoted prices which would be determined by the buyer based on its own assessment of reasonableness and based on competitive prices received in Bid / RA process.

### एक्सेल में अपलोड किए जाने की आवश्यकता /Excel Upload Required :

financial price breakup - [1775046653.xlsx](#)

### अतिरिक्त योग्यता /आवश्यक डेटा/Additional Qualification/Data Required

**Instruction To Bidder:**[1775046678.pdf](#)

**Scope of Work:**[1775046690.pdf](#)

Payment Terms:[1775046696.pdf](#)

GEM Availability Report ( GAR):[1775046704.pdf](#)

Undertaking of Competent Authority is mandatory to create Custom Bid for Services. Please download standard format document and upload:[1775046712.pdf](#)

Pre Qualification Criteria ( PQC ) etc if any required:[1775046723.pdf](#)

Project Experience and Qualifying Criteria Requirement:[1775046734.pdf](#)

## Custom Bid For Services - INSTALLATION OF CABLE TRAY SYSTEM FOR POND MOTOR ( 1 )

### तकनीकी विशिष्टियाँ /Technical Specifications

विवरण/ Specification	मूल्य/ Values
<b>कोर / Core</b>	
Description /Nomenclature of Service Proposed for procurement using custom bid functionality	INSTALLATION OF CABLE TRAY SYSTEM FOR POND MOTOR
Regulatory/ Statutory Compliance of Service	YES
Compliance of Service to SOW, STC, SLA etc	YES
<b>एडऑन /Addon(s)</b>	

### क्रेता द्वारा निर्धारित न्यूनतम मूल्य/Minimum Floor Price defined by Buyer

क्रेता द्वारा निर्धारित न्यूनतम मूल्य/Minimum Floor Price defined by Buyer	No
--	----

### अतिरिक्त विशिष्टि दस्तावेज़ /Additional Specification Documents

### परेषिती/रिपोर्टिंग अधिकारी /Consignees/Reporting Officer and Quantity

क्र.सं./S.N o.	परेषिती/रिपोर्टिंग अधिकारी /Consignee Reporting/Officer	पता/Address	Quantity	अतिरिक्त आवश्यकता /Additional Requirement
1	Sujith P M	682302,HOCL AMBALAMUGAL ERNAKULAM	Project / Lumpsum Based	N/A

### क्रेता द्वारा जोड़ी गई बिड की विशेष शर्तें/Buyer Added Bid Specific Terms and Conditions

#### 1. Generic

OPTION CLAUSE: The buyer can increase or decrease the contract quantity or contract duration up to 25 percent at the time of issue of the contract. However, once the contract is issued, contract quantity or

contract duration can only be increased up to 25 percent. Bidders are bound to accept the revised quantity or duration

## 2. **Purchase Preference (Centre)**

Purchase preference to Micro and Small Enterprises (MSEs): Purchase preference will be given to MSEs as defined in Public Procurement Policy for Micro and Small Enterprises (MSEs) Order, 2012 dated 23.03.2012 issued by Ministry of Micro, Small and Medium Enterprises and its subsequent Orders/Notifications issued by concerned Ministry. If the bidder wants to avail the Purchase preference, the bidder must be the manufacturer of the offered product in case of bid for supply of goods. Traders are excluded from the purview of Public Procurement Policy for Micro and Small Enterprises. In respect of bid for Services, the bidder must be the Service provider of the offered Service. Relevant documentary evidence in this regard shall be uploaded along with the bid in respect of the offered product or service. If L-1 is not an MSE and MSE Seller (s) has/have quoted price within L-1+ 15% of margin of purchase preference /price band defined in relevant policy, such Seller shall be given opportunity to match L-1 price and contract will be awarded for percentage of 100% of total value.

## 3. **Past Project Experience**

**Proof for Past Experience and Project Experience clause:** For fulfilling the experience criteria any one of the following documents may be considered as valid proof for meeting the experience criteria:a. Contract copy along with Invoice(s) with self-certification by the bidder that service/supplies against the invoices have been executed.b. Execution certificate by client with contract value.c. Any other document in support of contract execution like Third Party Inspection release note, etc.**Proof for Past Experience and Project Experience clause:** For fulfilling the experience criteria any one of the following documents may be considered as valid proof for meeting the experience criteria:a. Contract copy along with Invoice(s) with self-certification by the bidder that service/supplies against the invoices have been executed.b. Execution certificate by client with contract value.c. Any other document in support of contract execution like Third Party Inspection release note, etc.

## 4. **Service & Support**

**AVAILABILITY OF OFFICE OF SERVICE PROVIDER:** An office of the Service Provider must be located in the state of Consignee. **DOCUMENTARY EVIDENCE TO BE SUBMITTED.**

## 5. **Service & Support**

Dedicated /toll Free Telephone No. for Service Support : BIDDER/OEM must have Dedicated/toll Free Telephone No. for Service Support.

## 6. **Generic**

1. The Seller shall not assign the Contract in whole or part without obtaining the prior written consent of buyer.
2. The Seller shall not sub-contract the Contract in whole or part to any entity without obtaining the prior written consent of buyer.
3. The Seller shall, notwithstanding the consent and assignment/sub-contract, remain jointly and severally liable and responsible to buyer together with the assignee/ sub-contractor, for and in respect of the due performance of the Contract and the Sellers obligations there under.

## 7. **Buyer Added Bid Specific ATC**

Buyer uploaded ATC document [Click here to view the file.](#)

## 8. **Buyer Added Bid Specific ATC**

Buyer Added text based ATC clauses

Bidder should submit Complete set of Tender Document with Annexure (Buyer uploaded ATC document) duly filled in and signed by the Tenderer as prescribed in different clauses of the Tender Document .

Bidders should refer to the tender's pre-qualification criteria. Technical eligibility will be determined based on submission of relevant documents.

Vendors are requested to make a site visit before quoting.

The performance security shall be 5% (Five percent) of the total value of the contract.

## अस्वीकरण/Disclaimer

The additional terms and conditions have been incorporated by the Buyer after approval of the Competent Authority in Buyer Organization, whereby Buyer organization is solely responsible for the impact of these clauses on the bidding process, its outcome, and consequences thereof including any eccentricity / restriction arising in the bidding process due to these ATCs and due to modification of technical specifications and / or terms and conditions governing the bid. If any clause(s) is / are incorporated by the Buyer regarding following, the bid and resultant contracts shall be treated as null and void and such bids may be cancelled by GeM at any stage of bidding process without any notice:-

1. Definition of Class I and Class II suppliers in the bid not in line with the extant Order / Office Memorandum issued by DPIIT in this regard.
2. Seeking EMD submission from bidder(s), including via Additional Terms & Conditions, in contravention to exemption provided to such sellers under GeM GTC.
3. Publishing Custom / BOQ bids for items for which regular GeM categories are available without any Category item bunched with it.
4. Creating BoQ bid for single item.
5. Mentioning specific Brand or Make or Model or Manufacturer or Dealer name.
6. Mandating submission of documents in physical form as a pre-requisite to qualify bidders.
7. Floating / creation of work contracts as Custom Bids in Services.
8. Seeking sample with bid or approval of samples during bid evaluation process. (However, in bids for [attached categories](#), trials are allowed as per approved procurement policy of the buyer nodal Ministries)
9. Mandating foreign / international certifications even in case of existence of Indian Standards without specifying equivalent Indian Certification / standards.
10. Seeking experience from specific organization / department / institute only or from foreign / export experience.
11. Creating bid for items from irrelevant categories.
12. Incorporating any clause against the MSME policy and Preference to Make in India Policy.
13. Reference of conditions published on any external site or reference to external documents/clauses.
14. Asking for any Tender fee / Bid Participation fee / Auction fee in case of Bids / Forward Auction, as the case may be.
15. Any ATC clause in contravention with GeM GTC Clause 4 (xiii)(h) will be invalid. In case of multiple L1 bidders against a service bid, the buyer shall place the Contract by selection of a bidder amongst the L-1 bidders through a Random Algorithm executed by GeM system.
16. Buyer added ATC Clauses which are in contravention of clauses defined by buyer in system generated bid template as indicated above in the Bid Details section, EMD Detail, ePBG Detail and MII and MSE Purchase Preference sections of the bid, unless otherwise allowed by GeM GTC.
17. In a category based bid, adding additional items, through buyer added additional scope of work/ additional terms and conditions/or any other document. If buyer needs more items along with the main item, the same must be added through bunching category based items or by bunching custom catalogs or bunching a BoQ with the main category based item, the same must not be done through ATC or Scope of Work.

Further, if any seller has any objection/grievance against these additional clauses or otherwise on any aspect of this bid, they can raise their representation against the same by using the Representation window provided in the bid details field in Seller dashboard after logging in as a seller within 4 days of bid publication on GeM. Buyer is duty bound to reply to all such representations and would not be allowed to open bids if he fails to reply to such representations.

**All GeM Sellers/Service Providers shall ensure full compliance with all applicable labour laws, including the provisions, rules, schemes and guidelines under the four Labour Codes i.e. the Code**

on Wages, 2019; the Industrial Relations Code, 2020; the Occupational Safety, Health and Working Conditions Code, 2020; and the Code on Social Security, 2020 as and when notified and brought into force by the Government of India.

**For all provisions of the Labour Codes that are pending operationalisation through rules, schemes or notifications, the corresponding provisions of the pre-existing labour enactments (such as The Minimum Wages Act, 1948, The Payment of Wages Act, 1936, The Payment of Bonus Act, 1965, The Equal Remuneration Act, 1976, The Payment of Gratuity Act, 1972, etc. and relevant State Rules) shall continue to remain applicable.**

**The Seller/ Service Providers shall, therefore, be responsible for ensuring compliance under:**

- **All notified and enforceable provisions of the new Labour Codes as mentioned hereinabove; and**
- **All operative provisions of the erstwhile Labour Laws until their complete substitution.**

**All obligations relating to wages, social security, safety, working conditions, industrial relations etc. and any other statutory requirements shall be strictly met by the Seller/ Service Provider. Any non-compliance shall constitute a breach of the contract and shall entitle the Buyer to take appropriate action in accordance with the contract and applicable law.**

This Bid is governed by the [सामान्य नियम और शर्तें/General Terms and Conditions](#), conditions stipulated in Bid and [Service Level Agreement](#) specific to this Service as provided in the Marketplace. However in case if any condition specified in सामान्य नियम और शर्तें/General Terms and Conditions is contradicted by the conditions stipulated in Service Level Agreement, then it will over ride the conditions in the General Terms and Conditions.

जेम की सामान्य शर्तों के खंड 26 के संदर्भ में भारत के साथ भूमि सीमा साझा करने वाले देश के बिडर से खरीद पर प्रतिबंध के संबंध में भारत के साथ भूमि सीमा साझा करने वाले देश का कोई भी बिडर इस निविदा में बिड देने के लिए तभी पात्र होगा जब वह बिड देने वाला सक्षम प्राधिकारी के पास पंजीकृत हो। बिड में भाग लेते समय बिडर को इसका अनुपालन करना होगा और कोई भी गलत घोषणा किए जाने व इसका अनुपालन न करने पर अनुबंध को तत्काल समाप्त करने और कानून के अनुसार आगे की कानूनी कार्रवाई का आधार होगा।/In terms of GeM GTC clause 26 regarding Restrictions on procurement from a bidder of a country which shares a land border with India, any bidder from a country which shares a land border with India will be eligible to bid in this tender only if the bidder is registered with the Competent Authority. While participating in bid, Bidder has to undertake compliance of this and any false declaration and non-compliance of this would be a ground for immediate termination of the contract and further legal action in accordance with the laws.

---धन्यवाद/Thank You---



हिन्दुस्तान ऑर्गेनिक केमिकल्स लिमिटेड  
HINDUSTAN ORGANIC CHEMICALS LIMITED

(भारत सरकार का उद्यम)

(A Government of India Enterprise)

अंबलमुगल, एर्नाकुलम जिला, पिन - 682 302

AMBALAMUGAL, Ernakulam District, PIN – 682 302.

फोन: (0484) 2720911, Phone: (0484) 2720911

**निविदा संदर्भ संख्या: TENDER REF. NO: HOC/ELE/W&P/7095/25**

**कार्य का नाम: तालाब मोटर के लिए केबल ट्रे सिस्टम की स्थापना**

**NAME OF WORK: INSTALLATION OF CABLE TRAY SYSTEM FOR POND MOTOR**

**निविदा के सामान्य नियम और शर्तें GENERAL TERMS AND CONDITIONS OF THE TENDER**

*इस दस्तावेज़ को बोलीदाता द्वारा सभी पृष्ठों पर हस्ताक्षरित और सील किया जाना चाहिए और ई-निविदा के साथ प्रस्तुत किया जाना चाहिए  
THIS DOCUMENT TO BE SIGNED AND SEALED BY BIDDER ON ALL PAGES AND SUBMITTED ALONG WITH THE E-TENDER*

*बोलीदाताओं से अनुरोध है कि वे GeM पोर्टल से संपूर्ण निविदा दस्तावेज डाउनलोड करें तथा यह सुनिश्चित करें कि सभी दस्तावेज डाउनलोड हो गए हैं।*

Bidders are requested to download the complete tender documents from the GeM portal and ensure that all the documents are downloaded.

*कृपया अपनी ई-बोली दो-बोली प्रणाली के तहत विनिर्देशों और नियमों व शर्तों के अनुरूप प्रस्तुत करें।*

Please submit your e-bids under the **Two-bid System** conforming to the specifications and terms and conditions.

*बोली दस्तावेज़ में उल्लिखित खरीद की कुल मात्रा (1) एकमुश्त आधारित किराये को दर्शाती है। बोलीदाता को उद्धृत दर के रूप में कुल योग (सभी समावेशी) दर्ज करना चाहिए।*

The Total quantity of procurement (1) mentioned in Bid Document indicates Lumpsum based hiring. Bidder should enter the grand total (All inclusive) as the quoted rate.

*बोलीदाताओं से अनुरोध है कि वे ध्यान दें कि कीमतें केवल GeM पोर्टल पर उपलब्ध मूल्य प्रारूप (BOQ) में ही दर्ज की जानी हैं। बोलीदाता को GeM बोली के माध्यम से मांगे गए वित्तीय दस्तावेजों के साथ एक्सेल और पीडीएफ प्रारूप में विधिवत भरी, हस्ताक्षरित और सीलबंद BOQ शीट अपलोड करनी होगी।*

Bidders are requested to note that, the prices are to be entered only in the Price format (BOQ) available in the GeM portal. Bidder has to upload the BOQ sheet duly filled, signed and sealed in both in Excel and PDF format along with the financial documents sought through the GeM bid.

**पूर्व-योग्यता मानदंड (तकनीकी बोली में शामिल किया जाएगा)**

**PRE-QUALIFICATION CRITERIA (TO BE INCLUDED IN THE TECHNICAL BID)**

1. निविदा दस्तावेज के विभिन्न खंडों में निर्धारितानुसार निविदाकर्ता द्वारा विधिवत भरा गया और हस्ताक्षरित अनुलग्नक सहित निविदा दस्तावेज का पूरा सेट  
Complete set of Tender Document with Annexure duly filled in and signed by the Tenderer as prescribed in different clauses of the Tender Document.
2. बोलीदाता के पास उपकरण रखरखाव और मरम्मत कार्यों को संभालने के लिए पर्याप्त संख्या में सुयोग्य कार्यबल होना चाहिए। कर्मचारियों/श्रमिकों का विवरण प्रस्तुत किया जाना चाहिए।  
The bidder should have well qualified workforce in adequate numbers for handling equipment maintenance and repairing works. The staff/workers details are to be furnished.
3. बोलीदाता के पास निर्धारित समय के भीतर कार्य के निष्पादन के लिए पर्याप्त संख्या में उपकरण/औजार/उपकरण अच्छी स्थिति में होने चाहिए।  
The bidder should have adequate number of equipments/tools/tackles in sound condition for the execution of the work within the stipulated time.
4. निविदा की खंड संख्या और पृष्ठ संख्या के संदर्भ में अपवाद और विचलन, यदि कोई हो, एक अलग विवरण (विचलन विवरण) के रूप में प्रस्तुत किया जाएगा।  
Exceptions and deviations, if any, with reference to the Clause No. and page No. of Tender shall be submitted as a separate statement (Deviation Statement)
5. एमएसएमई के मामले में आवश्यक प्रमाण पत्र (स्व-सत्यापित) प्रस्तुत करना होगा।  
In the case of MSME, necessary certificate (self attested) shall be submitted.
6. कोई अन्य तकनीकी जानकारी जो निविदाकर्ता देना चाहे।  
Any other technical information the Tenderer likes to furnish.
7. बोली लगाने वाले के पास विद्युत स्थापना कार्य करने के लिए राज्य विद्युत लाइसेंसिंग बोर्ड द्वारा जारी वैध विद्युत ठेकेदार लाइसेंस (ए-क्लास/बी-क्लास) होना चाहिए। बोली लगाने वाले के पास विद्युत ठेकेदार लाइसेंस के प्रासंगिक पृष्ठों की प्रतियां तकनीकी बोलियों के साथ प्रस्तुत की जानी चाहिए।  
The bidder shall possess a valid Electrical contractor license (A-class/B-class) issued by the State Electricity Licensing Board for carrying out electrical installation works. Copies of the relevant pages of the Electrical Contractor License possessed by the bidder shall be furnished along with technical bids.

8. बोलीदाता के पास पिछले 7 वर्षों के दौरान सफलतापूर्वक पूर्ण किए गए समान कार्यों का अनुभव होना चाहिए, जो कि बोलियां आमंत्रित किए जाने वाले महीने के पिछले महीने के अंतिम दिन तक होना चाहिए, जो कि निम्न में से कोई एक होना चाहिए:

The bidder shall have experience of successfully completed similar works during last 7 years ending last day of month previous to the one in which bids are invited should be either of the following:

तीन समान पूर्ण किए गए कार्य जिनकी लागत **₹1,70,000** के बराबर से कम न हो

Three similar completed works costing not less than the amount equal to **₹1,70,000**

या or

दो समान पूर्ण किए गए कार्य जिनकी लागत **₹2,10,000** के बराबर से कम न हो

Two similar completed works costing not less than the amount equal to **₹2,10,000**

या or

एक समान पूर्ण कार्य जिसकी लागत **₹3,40,000** के बराबर से कम न हो

One similar completed works costing not less than the amount equal to **₹3,40,000**

**समान कार्य का अर्थ है किसी भी केंद्रीय/राज्य सरकार संगठन/पीएसयू/सार्वजनिक सूचीबद्ध कंपनी में केबल ट्रे स्थापना/प्रतिस्थापन और केबल बिछाने के कार्य में पिछला अनुभव। अनुभव प्रमाण पत्र/अनुबंध/कार्यदेश/सफल निष्पादन/पूर्णता के दस्तावेजी साक्ष्य की प्रतियां संलग्न की जानी चाहिए।**

**Similar works means past experience in cable tray installation/replacement and cable laying works to any Central / State Govt. Organization/ PSU/ Public Listed Company. Copies of experience certificates / Contracts / workorders / documentary evidence of successful execution / completion to be attached.**

बोलीदाता का पिछले वित्तीय वर्ष की 31 मार्च को समाप्त होने वाले पिछले 3 वर्षों के दौरान औसत वार्षिक वित्तीय कारोबार कम से कम **₹1,70,000** होना चाहिए। दस्तावेजी प्रमाण हस्ताक्षरित, मुहरबंद, स्कैन और अपलोड किए जाने चाहिए। (एमएसई पर लागू नहीं)

Average annual financial turnover of the bidder during the last 3 years ending 31<sup>st</sup> March of the previous financial year, should be at least **₹1,70,000**. Documentary proof to be signed, stamped, scanned and uploaded. (NOT APPLICABLE TO MSE)

9. सेवा प्रदाता का कार्यालय प्राप्तकर्ता के राज्य में स्थित होना चाहिए। दस्तावेजी साक्ष्य प्रस्तुत किए जाने चाहिए।

An office of service provider must be located in the state of Consignee. Documentary evidence to be submitted.

## **बयाना राशि EARNEST MONEY DEPOSIT**

प्रस्ताव के साथ 12,600/- (केवल बारह हजार छह सौ रुपये) की ईएमडी राशि जमा करनी होगी। यह राशि IRDAI के तहत बीमा कंपनी से जारी बीमा जमानत बांड (ISB) / खाताधारक डिमांड ड्राफ्ट / भारत में किसी भी अनुसूचित बैंक से जारी बैंक गारंटी जिसकी कोच्ची, केरल में शाखा हो / स्वीकार्य रूप में ऑनलाइन भुगतान के रूप में जमा करनी होगी।

The offer should be accompanied with an EMD amount of **12,600/- (Rupees Twelve Thousand Six Hundred Only)** shall be submitted. The amount shall be required to be submitted as Insurance Surety Bond (ISB) issued from Insurance Company under IRDAI / Account Payee Demand Draft / Bank Guarantee issued from any Scheduled Bank in India having a branch in Kochi, Kerala / on online payment in an acceptable form.

आपके प्रस्ताव में बैंक हस्तांतरण का विवरण दर्शाया जाना चाहिए।

Details of bank transfer should be indicated in your offer.

### **HOC bank details for NEFT**

**Bank Name: State Bank of India**

**Account No: 37881840330**

**IFSC Code: SBIN0013551**

**Branch Name: Belapur, Mumbai**

बैंक हस्तांतरण का विवरण आपके तकनीकी प्रस्ताव में दर्शाया जाना चाहिए। ईएमडी प्रस्तुत करने के लिए बैंक गारंटी प्रारूप अनुलग्नक एम में दर्शाया गया है। ईएमडी के साथ न दिए गए कोटेशन को अस्वीकार किया जा सकता है।

Details of bank transfer should be indicated in your technical offer. Bank Guarantee format for Furnishing EMD is shown in Annexure M. Quotations not accompanied with EMD, are liable to be rejected.

एनएसआईसी/एमएसएमई/एसएसआई इकाइयों के साथ पंजीकृत पीएसयू और विक्रेताओं को ईएमडी जमा करने की आवश्यकता नहीं है, लेकिन उन्हें तकनीकी-वाणिज्यिक बोली के साथ वैध एनएसआईसी पंजीकरण/छूट प्रमाणपत्र और बोली सुरक्षा घोषणा (अनुलग्नक एच) जमा करना होगा। एनएसआईसी के साथ पंजीकृत विक्रेता पर ऑर्डर अंतिम रूप दिए जाने की स्थिति में, विक्रेताओं को अनुबंध के संतोषजनक प्रदर्शन के लिए देय सुरक्षा जमा का भुगतान करना होगा।

PSUs and Vendors registered with NSIC/MSME/SSI Units need not submit EMD, but have to submit valid NSIC registration/exemption certificate and Bid Security Declaration (Annexure H) along with the Techno-commercial bid. In the event of order being finalised on vendor registered with NSIC, the vendors have to pay Security Deposit payable for the satisfactory performance of the contract.

सभी असफल निविदाकर्ताओं द्वारा प्रस्तुत ईएमडी उन्हें अनुबंध दिए जाने के 30वें दिन तक बिना किसी ब्याज के वापस कर दी जाएगी।

EMD furnished by all unsuccessful tenderers shall be returned to them without any interest latest on or before the 30th day after the award of contract.

सफल बोलीदाता की ईएमडी उनसे प्रदर्शन सुरक्षा प्राप्त करने के बाद बिना किसी ब्याज के वापस कर दी जानी चाहिए। वैकल्पिक रूप से, सफल बोलीदाता की ईएमडी को प्रदर्शन सुरक्षा/सुरक्षा जमा में समायोजित किया जाएगा, यदि वे अनुरोध करते हैं।

EMD of the successful tenderer should be returned without any interest whatsoever after receipt of performance security from them. Alternatively, EMD of the successful bidder shall be adjusted to the Performance Security/ Security Deposit, if requested by them.

**निम्नलिखित शर्तों के तहत निविदाकर्ता की संपत्ति जब्त कर ली जाएगी: -**

**EMD of the tenderer will be forfeited under the following conditions: -**

1. निविदा खुलने के पश्चात ठेकेदार निर्धारित अवधि/वैधता अवधि के अन्दर अपनी निविदा निरस्त कर देते हैं अथवा अपनी पूर्व उद्धृत दरों में वृद्धि कर देते हैं।  
After opening the tender, the contractors revoke their tender within the stipulated period / validity period or increase their earlier quoted rates.
2. ठेकेदार को काम का ठेका दिए जाने के बाद भी वह काम शुरू नहीं करता।  
Contractor does not commence the work after it is being awarded to them.
3. निविदाकर्ता निविदा की वैधता अवधि के भीतर अपनी निविदा वापस लेता है या उसमें संशोधन करता है या किसी भी प्रकार से निविदा को कमजोर या अवमूल्यित करता है।  
The tenderer withdraws or amends its tender or impairs or derogates from the tender in any respect within the period of validity of the tender.
4. सफल निविदाकर्ता निर्दिष्ट अवधि के भीतर अपेक्षित निष्पादन सुरक्षा प्रस्तुत करने में विफल रहता है।  
The successful tenderer fails to furnish the required performance security within the specified period.

**वस्तु एवं सेवा कर (जीएसटी) GOODS AND SERVICE TAX(GST)**

जिनके पास जीएसटीआईएन पंजीकरण है, उन्हें लागू वस्तु एवं सेवा कर (जीएसटी) अतिरिक्त देना होगा, जब तक कि अन्यत्र अन्यथा निर्दिष्ट न किया गया हो।

Goods and Service Tax (GST) applicable shall be paid extra, to those who have GSTIN registration, unless otherwise specified elsewhere.

**ईएसआई, पीएफ, श्रम कानून, एसएचई (सुरक्षा, स्वास्थ्य और पर्यावरण) आदि, आवश्यकताएँ**

**ESI, PF, LABOUR LAW, SHE (Safety, Health & Environment) etc., Requirements**

संलग्न अनुलग्नक ए, बी सी एवं डी देखें।

Refer Annexure A, B C and D attached.

**विवादों की मध्यस्थता ARBITRATION OF DISPUTES**

इस निविदा/समझौते/खरीद आदेश/कार्य आदेश से उत्पन्न होने वाले या उससे संबंधित सभी विवादों, मतभेदों, प्रश्नों और दावों को आपसी चर्चा के माध्यम से पार्टियों के बीच सौहार्दपूर्ण ढंग से सुलझाया जाएगा और ऐसा न होने पर, ऐसे विवादों, मतभेदों, प्रश्नों या दावों को मध्यस्थता के माध्यम से समाधान के लिए भारत अंतर्राष्ट्रीय मध्यस्थता केंद्र या एचओसीएल के अध्यक्ष-सह-प्रबंध निदेशक द्वारा नियुक्त किए जाने वाले एकमात्र मध्यस्थ को भेजा जाएगा और मध्यस्थता का पुरस्कार अंतिम और पार्टियों पर बाध्यकारी होगा। मध्यस्थता की सीट कोच्चि, केरल, भारत में होगी और मध्यस्थता की कार्यवाही भारत अंतर्राष्ट्रीय मध्यस्थता केंद्र अधिनियम 2019 / भारतीय मध्यस्थता और सुलह अधिनियम 1996 या वर्तमान में लागू किसी भी वैधानिक संशोधन या पुनः अधिनियमन के अनुसार कोच्चि, केरल, भारत में आयोजित की जाएगी।

All disputes, differences, questions and claims arising out of, under or touching upon this Tender/Agreement/Purchase Order/Work Order shall be settled amicably between the parties through mutual discussion and failing that, such disputes, difference, questions or claims shall be referred for resolution through arbitration to the India International Arbitration Centre or a Sole Arbitrator to be appointed by the Chairman-cum-Managing Director of HOCL and the award of Arbitration shall be final and binding on the parties. The seat of the Arbitration shall be at Kochi, Kerala, India and the proceedings of the arbitration shall be held at Kochi, Kerala, India in accordance with the India International Arbitration Centre Act 2019 / Indian Arbitration & Conciliation Act 1996 or any statutory modification or re-enactment thereof for the time being in force.

जब अनुबंध विदेशी विक्रेता के साथ होता है, तो विक्रेता के पास भारत अंतर्राष्ट्रीय मध्यस्थता केंद्र अधिनियम 2019 / भारतीय मध्यस्थता और सुलह अधिनियम, 1996 / UNCITRAL (अंतर्राष्ट्रीय व्यापार कानून मध्यस्थता पर संयुक्त राष्ट्र आयोग) मध्यस्थता नियमों के प्रावधानों के अनुसार मध्यस्थता चुनने का विकल्प होता है।

When the contract is with foreign vendor, the vendor has the option to choose arbitration in accordance with the provisions of The India International Arbitration Centre Act 2019 / The

Indian Arbitration and Conciliation Act, 1996 / UNCITRAL (United Nations Commission on International Trade Law Arbitration) Arbitration Rules.

### **सुरक्षा जमा राशि SECURITY DEPOSIT**

कुल सुरक्षा जमा राशि कुल अनुबंध मूल्य का 5% (पांच प्रतिशत) होगी। इसे प्रत्येक चालू खाता बिल के मूल्य के 5% (पांच प्रतिशत) की दर से कटौती के माध्यम से वसूल किया जाएगा, जब तक कि कुल सुरक्षा जमा राशि एकत्र नहीं हो जाती, जिसके बाद इस खाते में कोई और कटौती नहीं की जाएगी। केवल एक बिल के मामले में, बिल से 5% (पांच प्रतिशत) की कटौती की जाएगी।

Total Security deposit shall be 5% (Five percent) of the total contract value. This shall be recovered through deductions at the rate of 5% (Five percent) of the value of each running account bill till the total security deposit amount is collected, after which no further deductions shall be made on this account. In case of only one bill, 5% (five percent) shall be deducted from the bill.

सुरक्षा जमा को भारत में कोच्चि, केरल में शाखा वाले किसी अनुसूचित बैंक से जारी खाताधारक डिमांड ड्राफ्ट / बैंक गारंटी (ई-बैंक गारंटी सहित) / ऑनलाइन भुगतान / आईआरडीएआई के तहत बीमा कंपनी से जारी बीमा जमानत बांड (आईएसबी) के रूप में प्रस्तुत किया जा सकता है।

Security deposit may be furnished in the form of Account Payee Demand Draft / Bank Guarantee (including e-Bank Guarantee) issued from a Scheduled Bank in India having a branch in Kochi, Kerala/on online payment/Insurance Surety Bond (ISB) issued from Insurance Company under IRDAI.

सुरक्षा जमा राशि, अनुबंध के पूर्ण होने के पश्चात/अंतिम बिल के साथ, बिना किसी ब्याज के ठेकेदार को वापस कर दी जाएगी, परंतु अनुबंध के अंतर्गत सभी दायित्वों के पूर्ण होने के 60 दिनों के भीतर।

Security Deposit shall be refunded to the contractor without any interest after the completion of contract in all respects / along with final bill but not later than 60 days of completion of all such obligations under the contract.

### **निष्पादन सुरक्षा PERFORMANCE SECURITY**

निष्पादन सुरक्षा राशि अनुबंध के कुल मूल्य का 5% (पांच प्रतिशत) होगी। इसे अनुबंध की अधिसूचना के 21 दिनों के भीतर प्रस्तुत किया जाना चाहिए और दोष दायित्व अवधि के बाद जारी किया जाना चाहिए।

The performance security shall be 5% (Five percent) of the total value of the contract. It shall be furnished within 21 days after notification of award and shall be released after the defect liability period.

निष्पादन सुरक्षा को भारत में कोच्चि, केरल में शाखा वाले किसी अनुसूचित बैंक से जारी खाताधारक डिमांड ड्राफ्ट / बैंक गारंटी (ई-बैंक गारंटी सहित) / ऑनलाइन भुगतान / आईआरडीएआई के तहत बीमा कंपनी से जारी बीमा जमानत बांड (आईएसबी) के रूप में प्रस्तुत किया जा सकता है।

Performance security may be furnished in the form of Account Payee Demand Draft / Bank Guarantee (including e-Bank Guarantee) issued from a Scheduled Bank in India having a branch in Kochi, Kerala/on online payment/Insurance Surety Bond (ISB) issued from Insurance Company under IRDAI.

### **परिसमापन हर्जाना LIQUIDATED DAMAGES**

LD ऑर्डर वैल्यू का 0.5% प्रति सप्ताह होगा, जो ऑर्डर वैल्यू के अधिकतम 5% के अधीन होगा, बशर्ते देरी के लिए संबंधित पार्टी जिम्मेदार हो।

LD shall be @ 0.5% per week of the order value subject to a maximum of 5% of the order value, provided the delay is attributable by the party.

### **पूरा होने का समय TIME OF COMPLETION**

काम अप्रैल 2026 के पहले हफ्ते में शुरू होगा। काम लगातार चलता रहेगा। पूरा काम काम शुरू होने की तारीख से 30 दिनों के अंदर पूरा हो जाएगा।

The work shall be commenced on 1st week of April 2026. The works shall be continuous in nature. Entire work shall be completed within 30 days from date of starting the work.

### **अनुबंध की अवधि PERIOD OF CONTRACT**

कॉन्ट्रैक्ट की अवधि वर्क ऑर्डर जारी होने की तारीख से नौ महीने है।

Period of contract is **Nine months** from date of issue of work order.

### **SCOPE OF SUPPLY**

सामग्री MATERIAL: -

FRP केबल लैडर, केबल लैडर एक्सेसरीज़, केबल लैडर फिटिंग्स, M.S स्ट्रक्चरल, पेंटिंग मटीरियल, कंज्यूमेबल्स जैसे सभी मटीरियल ठेकेदार बिना किसी अतिरिक्त लागत के सप्लाई करेगा।

All the materials such as FRP cable ladder, Cable Ladder accessories, Cable ladder fittings, M.S structural, Painting materials, Consumables shall be supplied by the contractor without any additional cost.

एचओसीएल आपूर्ति का दायरा HOCL Scope of Supply: शून्य Nil.

उपकरण एवं टैकल TOOLS & TACKLES: -

ठेकेदार का कार्यक्षेत्र: कार्य के लिए आवश्यक सभी उपकरण और साज-सामान की व्यवस्था ठेकेदार द्वारा की जानी है।

Contractor's Scope: All the tools & tackles required for the works are to be arranged by the contractor.

एचओसीएल आपूर्ति का दायरा HOCL Scope of Supply:

शून्य Nil.

### **ऑफर की वैधता VALIDITY OF OFFER**

निविदा प्राप्ति के लिए निर्धारित अंतिम तिथि से तीन माह की अवधि तक निविदा को स्वीकृति हेतु वैध रखा जाएगा।

The tender shall be kept valid for acceptance for a period of **THREE** months from the last date prescribed for receipt of the tender.

कोई भी निविदाकर्ता उक्त तीन माह की अवधि के दौरान कम्पनी की लिखित सहमति के बिना अपनी निविदा को रद्द करने या प्रतिसंहत दर या उसकी किसी शर्त में परिवर्तन करने का हकदार नहीं होगा।

A Tenderer shall not be entitled during the said period of three months without the consent in writing of the company to revoke or cancel his tender or to vary the tendered rate or any terms thereof.

### **भुगतान की शर्तें PAYMENT TERMS**

भुगतान, निष्पादित मात्रा के आधार पर प्रभारी अभियंता की अनुशंसा पर तथा कार्य आदेश में उल्लिखित कटौती करने के पश्चात, 30 दिनों के भीतर बिल प्रस्तुत करने के पश्चात किया जाएगा।

Payment will be made after submission of bill within 30 days, on recommendations of the Engineer-in-charge based on the quantities executed and after making deductions as spelt out in the work order.

### **दोष दायित्व अवधि DEFECT LIABILITY PERIOD**

ठेकेदार को कार्य समाप्ति की तिथि से 6 माह की अवधि के लिए सम्पूर्ण कार्य की गारंटी देनी होगी, ठेकेदार द्वारा आपूर्ति किये गये उपकरण या सामग्री से किसी भी प्रकार से जुड़ी हुई मरम्मत या प्रतिस्थापन ठेकेदार द्वारा अपने व्यय पर किया जाएगा, जैसा कि प्रभारी इंजीनियर द्वारा आवश्यक समझा जाएगा।

The contractor shall guarantee the entire work for a period of 6 months from date of completion of work, connected in any way with the equipment or materials supplied by contractor or in the workmanship shall be rectified or replaced by contractor at his own expense as deemed necessary by the Engineer-In-Charge.

### **अनुबंध वरीयता CONTRACT PREFERENCE**

एमएसएमई/एसएसआई इकाइयों/पीएसयू के लिए लागू अनुबंध/मूल्य वरीयता या कोई अन्य रियायतें भारत सरकार के नवीनतम निर्देशों के अनुसार होंगी। इस लाभ को प्राप्त करने के लिए, बोलीदाता को

तकनीकी बोली में ही अपना दावा करना होगा और अपनी पात्रता साबित करने के लिए आवश्यक दस्तावेजी साक्ष्य संलग्न करने होंगे।

Contract / Price Preference or any other concessions applicable for **MSME / SSI Units /PSUs** will be as per latest Government of India Directives. For availing this benefit, the bidder shall make their claim in the Technical Bid itself and enclose necessary documentary evidence to prove their eligibility.

### **दर RATE**

दरें (BOQ) में उद्धृत की जाएंगी और इसे ऑनलाइन जमा करना होगा। उद्धृत दरों में सभी कर, शुल्क, चुंगी, जीएसटी सहित अन्य शुल्क शामिल होंगे। हालांकि लागू जीएसटी का भुगतान एचओसीएल द्वारा किया जाएगा, बशर्ते कि सफल निविदाकर्ता के पास केंद्रीय उत्पाद शुल्क के साथ जीएसटी पंजीकरण हो।

The rates shall be quoted in (BOQ) and submit it online. Rates quoted shall be inclusive of all taxes, duties, octroi, other levies, including GST. However applicable GST will be paid by HOCL subject to the successful tenderer having GST registration with Central Excise.

कीमत अंकों और शब्दों दोनों में उद्धृत की जानी चाहिए। यदि किसी निविदाकर्ता ने शब्दों और अंकों में दो अलग-अलग कीमतें उद्धृत की हैं, तो उनमें से कम कीमत को वैध माना जाएगा और वह निविदाकर्ता के लिए बाध्यकारी होगी।

The price shall be quoted both in figures and words. In case a tenderer has quoted two different prices in words and figures the lower of the two will be considered valid and binding on the tenderer.

### **अन्य नियम और शर्तें OTHER TERMS AND CONDITIONS**

#### **एचओसीएल के अनुबंध की सामान्य शर्तें (जीसीसी)**

#### **GENERAL CONDITIONS OF CONTRACT (GCC) OF HOCL**

अन्य सभी नियम और शर्तें हमारी वेबसाइट पर प्रकाशित अनुबंध की सामान्य शर्तों और अनुबंध की विशेष शर्तों के अनुसार होंगी। जीसीसी और अनुबंध की विशेष शर्तों को सभी कार्य दिवसों में कार्यालय समय के दौरान हमारे कार्यालय में भी देखा जा सकता है।

All other Terms and Conditions will be as per our General Conditions of Contract, as published in our website and special condition of contract. The GCC and Special conditions of contract can also be referred in our office during office hours in all working days.

अनुबंध की सामान्य शर्तें (जीसीसी) [www.hoclkochi.com](http://www.hoclkochi.com) पर उपलब्ध हैं।

The General Conditions of Contract (GCC) is available on [www.hoclkochi.com](http://www.hoclkochi.com).

### **बोली अस्वीकार करने का अधिकार RIGHT TO REJECT A BID:**

एचओसीएल निम्नलिखित कारणों से किसी भी बोली को अस्वीकार करने का अधिकार सुरक्षित रखता है:

HOCL reserves the right to reject any bid due to reasons such as

- a. विक्रेता द्वारा उपरोक्त बोली प्रक्रिया का पालन न करना  
Vendor not following above bidding procedures
- b. विक्रेता का एचओसीएल को तकनीकी रूप से स्वीकार्य न होना  
Vendor not being technically acceptable to HOCL
- c. विक्रेता निविदा की सामान्य शर्तों से सहमत न होना।  
Vendor not agreeing with the general conditions of the tender.
- d. मांगे गए किसी विशेष दस्तावेज को संलग्न न करना।  
Not enclosing any particular documents asked for.
- e. कोई अन्य वैध कारण.  
Any other valid reasons.

### **सामान्य साइट सफ़ाई GENERAL SITE CLEANING**

कार्य स्थल को हमेशा प्रभारी अभियंता की संतुष्टि के अनुसार साफ-सुथरा रखा जाना चाहिए। कार्य पूरा होने पर सभी सामग्रियों को दैनिक आधार पर प्रभारी अभियंता के निर्देशानुसार एचओसीएल परिसर में निर्दिष्ट स्थानों पर ले जाया जाएगा। बिल जमा करने से पहले सामग्री का मिलान किया जाना चाहिए।

Working site should always be kept cleaned up to the entire satisfaction of the Engineer-In-Charge. Upon completion of the work all materials shall be transported to designated locations in HOCL premises as directed by the Engineer-In-Charge on daily basis. Material reconciliation has to be carried before submitting the bill.

### **समझौता AGREEMENT**

शून्य Nil.

### **बोलियों के सभी पृष्ठों पर हस्ताक्षर और मुहर लगाना SIGNING AND SEALING ON ALL PAGES OF BIDS**

विक्रेता को अपलोड की गई बोलियों के सभी पृष्ठों पर हस्ताक्षर और मुहर लगानी होगी, अन्यथा बोलियां अस्वीकार कर दी जाएंगी।

The vendor shall sign and seal on all the pages of the bids uploaded, failing which bids are liable to be rejected.

### **प्रभारी अधिकारी OFFICER-IN-CHARGE**

श्री सुजीत पी एम Shri.Sujith P M  
प्रबंधक (विद्युत) Manager (Electrical)  
फ़ोन Ph: 0484 2727226  
ईमेल आईडी Email: [pm.sujith@hocl.gov.in](mailto:pm.sujith@hocl.gov.in)

**ध्यान दें Note:**

निविदा दस्तावेजों के हिन्दी और अंग्रेजी संस्करण में विवाद उत्पन्न होने की स्थिति में अंग्रेजी संस्करण ही मान्य होगा।

**In case of dispute arise in Hindi and English Version of the Tender documents, the english version will prevail.**



**हिन्दुस्तान ऑर्गेनिक केमिकल्स लिमिटेड**  
**HINDUSTAN ORGANIC CHEMICALS LIMITED**

(भारत सरकार का उद्यम)

(A Government of India Enterprise)

अंबलमुगल, एर्नाकुलम जिला, पिन - 682 302

AMBALAMUGAL, Ernakulam District, PIN – 682 302.

फोन: (0484) 2720911, Phone: (0484) 2720911

**निविदा संदर्भ संख्या: TENDER REF. NO: HOC/ELE/W&P/7095/25**

**कार्य का नाम: तालाब मोटर के लिए केबल ट्रे सिस्टम की स्थापना**

**NAME OF WORK: INSTALLATION OF CABLE TRAY SYSTEM FOR POND MOTOR**

**काम की गुंजाइश SCOPE OF WORK**

*इस दस्तावेज़ को बोलीदाता द्वारा सभी पृष्ठों पर हस्ताक्षरित और सील किया जाना चाहिए और ई-निविदा के साथ प्रस्तुत किया जाना चाहिए  
THIS DOCUMENT TO BE SIGNED AND SEALED BY BIDDER ON ALL PAGES AND SUBMITTED ALONG WITH THE E-TENDER*

In HOCL, Ambalamugal, Pond water pump motor cable is laid underground from Panel to the motor. During rainy season, area surrounding the Pond water motor is getting flooded, hence decided to install new overhead FRP cable tray system from Panel to the Motor. The scope includes supply and installation of FRP cable tray system, M.S supports etc. Detailed scope of work is given below.

**Supply and Installation of FRP Cable ladders**

The scope includes supply and Installation of FRP/GRP cable ladder of size 300mm width and 100mm height C shaped side runners with 4 mm thickness (heavy duty). Fiberglass ladder, fittings and accessories shall be manufactured in accordance with NEMA FG1 and ASTM E-84 standards. FRP/GRP cable ladder material shall be UV resistant, Corrosion resistant, fire retardant (class A fire rating in accordance with the latest ASTM E-84 standard). An additive material shall be mixed with fiberglass to make them resistant to ultraviolet light. The minimum glass content in FRP material shall be 45%. The cable ladder linear length only mentioned in the BOQ. The quoted price shall be inclusive of all the necessary cable ladders, fittings, accessories etc. Copy of Type tests for Mechanical, Electrical and fire-retardant properties as per relevant ASTM standard, NEMA FG1 Shall be submitted. The standard length of FRP/GRP cable ladder shall be 3 meters. The thickness of FRP ladder C section and coupler plate shall be minimum 4 mm. Each cable ladder shall be supplied by 4 coupler plates, 16 nuts, 16 bolts and 32 washers. All hardwares shall be

stainless steel (SS316/SS304). The depth of cable ladder and accessories shall be 100mm. All the bends, offsets required as per site conditions preferably be ready made type or custom-made type. In addition, required supports of adequate size shall be provided in bends and offset areas of Cable ladders. All the cable ladders shall be secured on structural support using hold down bolts of adequate size. Cable ladder installation shall be as per NEMA FG1 standard. Preferred support span is on every 3 meters of ladder length (4 mm thick C section has considered considering the 3-meter span). For bends and other fittings, the support should be within 2 feet of each fitting extremity and one support must be located between the center member of the fittings. Offered Cable ladder and accessories shall match with GA drawing given along with the Tender document. The preferred make of FRP cable ladder is Ercon/Sumip.

## **2. Supply, Fabrication and Installation of M.s Supports for FRP Cable ladders**

The scope includes supply, fabrication, welding, shot blasting, painting and installation of M.S structural for Cable ladder supports. The dimension of M.S structural shall be suitably selected based on site conditions and as per the direction of Engineer in Charge. The quantity indicated in the Boq is approximate only, it may vary on either side. Payment shall be made on actual quantity executed. After completing fabrication and welding of Cable ladder supports, blasting and painting can be carried out. Surface preparation of M.S structural shall be as per standard SSPC-SP-10/NACE#2 ie. Blast cleaning to near white metal cleanliness, until at least 95% of each element of surface area is free of all visible residues with desired surface profile. Blast cleaned surface shall be coated with one complete application of primer as soon as practicable but in no case later than 4 hrs in same day. Shop primer coatings shall be applied by airless spray and intermediate primer and finish coats can be applied by brush. The shop primer shall be 1 coat of two component inorganic zinc silicate coating with a DFT of 65-75 $\mu$ . After applying shop primer, M.S structural can be brought out to site for installation works. After completing the installation works, an intermediate primer of 1 coat of two component epoxy zinc phosphate primer cured with polyamine hardener with a 40 $\mu$  DFT to be applied on all structural supports. The finish coat shall be 2 coats of High build epoxy finish coating cured with polyamine hardener @100 $\mu$  DFT/coat plus 1 coat of two component acrylic polyurethane finish paint @40 $\mu$  DFT. Thus, total DFT in Microns shall be 345-355.

### **Inspection and Testing**

All painting materials including primers and thinners brought to site by contractor for application shall be procured from reputed manufacturers as per specifications and shall be accompanied by manufacturer's test certificates.

The painting work shall be subject to inspection by Engineer-in-Charge at all times. In particular, following stage inspection will be performed and contractor shall offer the work for inspection and approval at every stage before proceeding with next stage. The record of inspection shall be maintained. Stages of inspection are as follows:

- a) Surface preparation
- b) Primer application
- c) Each coat of paint

Any defect noticed during the various stages of inspection shall be rectified by the contractor to the entire satisfaction of Engineer-in-Charge before proceeding further. Irrespective of the inspection, repair and approval at intermediate stages of work, contractor shall be responsible for making good any defects found during final inspection/guarantee period/defect liability period as defined in general condition of contract. Dry film thickness (DFT) shall be checked and recorded after application of each coat.

The installation of M. S structural involves concreting of cable tray support structural base in soil at a depth of approximately 1meter from finish floor level. The scope includes excavation, earth removal, shuttering and concreting. The cable tray supports shall be placed on every 3-meter distance. Additional support is required wherever cable tray bends are coming. The cable tray base structural shall be ISMC100(100x50x6 mm M.s channel) and proposed 300mm cable ladder can be placed above the channel on ISMC 75(75x40x4.8mm M.s channel) welded over the channel in 'T'shape format. Typical cable tray support installation drawing is enclosed for reference.

### **3.Excavation for Concreting of Cable tray Supports**

Providing Excavation up to 1-meter depth on normal and hard soil for the purpose of fixing and concreting M.S supports for Cable tray system near the Pond area. This include all labour, material and equipment necessary to carry out the excavation. Excavation shall be carried out as per the dimension shown in the drawing or as otherwise directed by the Engineer in Charge. The surplus excavated earth as a result of excavation shall be deposited near the surrounding area of pond or any other location near to it as shown by the Engineer

In charge. The quantity indicated in the tender is approximate only, it may vary on either side depending on the site conditions.

#### **4. Concreting of Cable tray supports**

Providing and laying plain cement concrete 1:2:4 (1 cement: 2 coarse sand: 4 graded stone aggregate 20mm nominal size) in foundation including shuttering, finishing, compacting, curing etc. All the material required for the concrete such as cement, coarse sand, 20mm aggregate etc. shall be arranged and sourced by the Contractor. The make of cement shall be Ultratech/Malabar cement. The quantity indicated in the tender is approximate only, it may vary on either side depending on the site conditions.

#### **Other terms and Conditions**

1. Vendors are requested to make a site visit before quoting.
2. Vendor shall arrange stage wise inspection of surface preparation, application of paint etc. We prefer the surface preparation and shop primer works at Ernakulam district or within the perimeter of 100 kms of HOCL, Ambalamugal.
3. Structural, Painting materials shall be of reputed make. The M.S structural shall be from makes such as TATA/ Vizag/ Jindal/ Appolo/ JSW and Painting materials shall be from Asian Paints/Bombay paints/Berger Paints/Goodlass Nerolac paints/Garware paints/Jenson and Nicholson/Shalimar paints. Vendor shall supply material test certificate for all the supplied Structural, Painting and Cable ladder systems.
4. The contractor shall guarantee the entire work for a period of 6 months from date of completion of work, connected in any way with the equipment or materials supplied by contractor or in the workmanship shall be rectified or replaced by contractor at his own expense as deemed necessary by the Engineer-In-Charge.
5. All the brought-out items shall be inspected by HOCL Engineer In charge prior to installation
6. The works shall be continuous in nature. Entire work shall be completed within 30 days from date of starting the work. The work shall be commenced before next Monsoon. The tentative date of work execution is on May first week 2026.



**हिन्दुस्तान ऑर्गेनिक केमिकल्स लिमिटेड**  
**HINDUSTAN ORGANIC CHEMICALS LIMITED**

(भारत सरकार का उद्यम)

(A Government of India Enterprise)

अंबलमुगल, एर्नाकुलम जिला, पिन - 682 302

AMBALAMUGAL, Ernakulam District, PIN – 682 302.

फोन: (0484) 2720911, Phone: (0484) 2720911

**निविदा संदर्भ संख्या: TENDER REF. NO: HOC/ELE/W&P/7095/25**

**कार्य का नाम: तालाब मोटर के लिए केबल ट्रे सिस्टम की स्थापना**

**NAME OF WORK: INSTALLATION OF CABLE TRAY SYSTEM FOR POND MOTOR**

**अनुपालन / नो-विचलन वक्तव्य COMPLIANCE / NO-DEVIATION STATEMENT**

*इस दस्तावेज़ को बोलीदाता द्वारा सभी पृष्ठों पर हस्ताक्षरित और सील किया जाना चाहिए और ई-निविदा के साथ प्रस्तुत किया जाना चाहिए*  
*THIS DOCUMENT TO BE SIGNED AND SEALED BY BIDDER ON ALL PAGES AND SUBMITTED ALONG WITH THE E-TENDER*

Tender ID:

एतद्वारा यह कहा गया है कि हमारे द्वारा प्रस्तुत कोटेशन/प्रस्ताव जांच के खिलाफ जारी किए गए सभी दस्तावेजों के पूर्ण अनुपालन में हैं और यह भी पुष्टि की है कि जांच के अनुसार सभी नियमों और शर्तों से कोई विचलन नहीं है।

It is hereby stated that the quotation/offer submitted by us is in full compliance with the documents issued against the enquiry and also further confirmed that there is no deviation from all the terms and conditions as per the enquiry.

निविदाकर्ता के हस्ताक्षर Signature of the Tenderer :

निविदाकर्ता का नाम Name of the Tenderer :

पता Address :

स्थान Place:

मोहर SEAL

दिनांक Date

**अनुबंध की सामान्य शर्तों (जीसीसी) का अनुपालन**

**COMPLIANCE OF GENERAL CONDITIONS OF CONTRACT (GCC)**

एतद्वारा यह कहा गया है कि हमने अनुबंध की सामान्य शर्तों (जीसीसी) को पढ़ा और समझा है और पुष्टि की है कि हम जीसीसी के सभी नियमों और शर्तों का पालन करते हैं।

It is hereby stated that we have read and understood General Conditions of Contract (GCC) and confirm that we abide by all the terms and conditions of GCC.

निविदाकर्ता के हस्ताक्षर Signature of the Tenderer :

निविदाकर्ता का नाम Name of the Tenderer :

पता Address :

स्थान Place:

मोहर SEAL

दिनांक Date:



**हिन्दुस्तान ऑर्गेनिक केमिकल्स लिमिटेड**  
**HINDUSTAN ORGANIC CHEMICALS LIMITED**

(भारत सरकार का उद्यम)

(A Government of India Enterprise)

अंबलमुगल, एर्नाकुलम जिला, पिन - 682 302

AMBALAMUGAL, Ernakulam District, PIN – 682 302.

फोन: (0484) 2720911, Phone: (0484) 2720911

**निविदा संदर्भ संख्या: TENDER REF. NO: HOC/ELE/W&P/7095/25**

**कार्य का नाम: तालाब मोटर के लिए केबल ट्रे सिस्टम की स्थापना**

**NAME OF WORK: INSTALLATION OF CABLE TRAY SYSTEM FOR POND MOTOR**

**प्रो-फॉर्मा-तकनीकी बोली PRO-FORMA-TECHNICAL BID**

*इस दस्तावेज़ को बोलीदाता द्वारा सभी पृष्ठों पर हस्ताक्षरित और सील किया जाना चाहिए और ई-निविदा के साथ प्रस्तुत किया जाना चाहिए*  
*THIS DOCUMENT TO BE SIGNED AND SEALED BY BIDDER ON ALL PAGES AND SUBMITTED ALONG WITH THE E-TENDER*

Name of Work: **INSTALLATION OF CABLE TRAY SYSTEM FOR POND MOTOR**

Reference: - Tender No: **HOC/HOC/ELE/W&P/7095/25**

1. **PAN No of the bidder:** .....
2. **GSTIN No of the bidder:** .....
3. **Contact Person Name and Mobile No.....**
4. **Email id for correspondence:** .....

**CHECK LIST** (put  $\checkmark$  mark in front of your confirmation)

1. General Terms and Conditions, Scope of Work (complete set of Tender Documents) to be signed and stamped on all pages, scanned and uploaded (**YES/NO**).
2. Proforma of Declaration of Black Listing/ Holiday Listing (Annexure D) - duly filled, signed and stamped, scanned and uploaded (**YES/NO**).
3. Bidder Information (Annexure - E) signed and stamped, scanned and uploaded (**YES/NO**).
4. Bid security Declaration (Annexure H) - duly filled, signed and stamped, scanned and uploaded. (**YES/NO**)
5. Declaration on Code of Integrity for Public Procurement (COIPP) (Annexure L) - duly filled, signed and stamped, scanned and uploaded (**YES/NO**).
6. Declaration of compliance of order (Annexure R) - duly filled, signed and stamped, scanned and uploaded (**YES/NO**).

7. Form of Declaration along with submission of tender (Annexure W) - duly filled, signed and stamped, scanned and uploaded (YES/NO).
8. Exceptions and deviations, if any, with reference to the Clause No. and page No. of Tender shall be submitted as a separate statement (Deviation Statement) (YES/NO).

निविदाकर्ता के हस्ताक्षर Signature of the Tenderer :

निविदाकर्ता का नाम Name of the Tenderer :

पता Address :

स्थान Place:

मोहर SEAL

दिनांक Date:



**हिन्दुस्तान ऑर्गेनिक केमिकल्स लिमिटेड**  
**HINDUSTAN ORGANIC CHEMICALS LIMITED**

(भारत सरकार का उद्यम)

(A Government of India Enterprise)

अंबलमुगल, एर्नाकुलम जिला, पिन - 682 302

AMBALAMUGAL, Ernakulam District, PIN – 682 302.

फोन: (0484) 2720911, Phone: (0484) 2720911

**निविदा संदर्भ संख्या: TENDER REF. NO: HOC/ELE/W&P/7095/25**

**कार्य का नाम: तालाब मोटर के लिए केबल ट्रे सिस्टम की स्थापना**

**NAME OF WORK: INSTALLATION OF CABLE TRAY SYSTEM FOR POND MOTOR**

**अनुबंध की विशेष शर्तें SPECIAL CONDITIONS OF CONTRACT**

*इस दस्तावेज़ को बोलीदाता द्वारा सभी पृष्ठों पर हस्ताक्षरित और सील किया जाना चाहिए और ई-निविदा के साथ प्रस्तुत किया जाना चाहिए*  
*THIS DOCUMENT TO BE SIGNED AND SEALED BY BIDDER ON ALL PAGES AND SUBMITTED ALONG WITH THE E-TENDER*

1. काम के लिए रखे गए मज़दूरों और सुपरवाइज़र के लिए सेफ्टी हेलमेट, सेफ्टी शूज़, गॉगल्स, सेफ्टी बेल्ट और दूसरे PPEs वगैरह का इंतज़ाम कॉन्ट्रैक्टर को करना होगा। दूसरे PPEs के अलावा, कॉन्ट्रैक्टर के रखे गए मज़दूरों को कंपनी की जगह में घुसने से पहले सेफ्टी हेलमेट और सेफ्टी शू दिए जाएँगे। इसका सख्ती से पालन करना होगा।  
Safety Helmets, safety shoes, goggles, safety belts and other PPEs etc. for the workmen and supervisor employed for the work are to be arranged by the contractor. In addition to the other PPEs, the labourers engaged by contractor shall be provided with safety helmet and safety shoe before entering the company premises. this shall be adhered strictly.
2. ठेकेदार के कर्मचारियों द्वारा सुरक्षा गैजेट (पीपीई), सीमित स्थान प्रवेश रिकॉर्ड और सुरक्षा कार्य परमिट पहने बिना कोई काम नहीं किया जाएगा।  
No work to be carried out without wearing safety gadgets (PPE's), confined space entry record and safety work permit by the employees of the contractor.
3. COVID-19 को फैलने से रोकने के लिए, आपके वर्कर्स को ये PPEs देना ज़रूरी है:  
As a measure to contain the spread of COVID-19, the following PPEs are essentially required to be provide to your workers:
  - a) फेस मास्क Face Mask
  - b) फेस शील्ड Face Shield
  - c) दस्तानेGloves
4. साथ ही, आपके सभी वर्कर्स की सिव्योरिटी में टेम्परेचर स्क्रीनिंग की जाएगी, एंट्रेस पर हैंड वॉश कराया जाएगा, और जितना हो सके फिजिकल डिस्टेंसिंग बनाए रखी जाएगी।

Also all your workers are to be subjected to temperature screening at Security, hand wash at the entrance, maintain physical distancing as far as possible.

5. आप अपने वर्कर्स को सख्ती से कहेंगे कि वे पब्लिक जगहों और काम की जगह पर न थूकें।  
You shall strictly instruct your workers not to spit in the public places and area of work.
6. अगर काम की प्रोग्रेस और क्वालिटी ठीक नहीं पाई जाती है, तो HOC को काम रोकने का पूरा अधिकार है।

HOC has every right to stop the work if the progress and quality of work is found unsatisfactory.

7. कॉन्ट्रैक्टर को काम शुरू करने के लिए, जानकारी मिलने के समय से सही समय के अंदर ज़रूरी टूल्स और सामान के साथ पूरी टीम को तैयार करना होगा।

Contractor has to mobilize the complete team with necessary tools and tackles within reasonable period from the time of intimation to start the work.

8. काम के दौरान कॉन्ट्रैक्टर या उसका ऑथराइज्ड सुपरवाइज़र काम की जगह पर मौजूद रहेगा।  
Either the contractor or his authorized supervisor shall be available at work site throughout the work.

9. काम के दौरान होने वाली किसी भी दुर्घटना से होने वाली लायबिलिटी के कवरेज के लिए कॉन्ट्रैक्टर को सही इंश्योरेंस का इंतज़ाम करना होगा।

Appropriate insurance shall be arranged by the contractor for the coverage of the liability to the people employed by them, arising out of any accident occurring during the execution of the work.

10. ठेकेदार अनुलग्नक – ए, बी और सी के सभी खंडों जैसे ईएसआई, सुरक्षा विनियम और अनुबंध की सामान्य शर्तें, श्रमिक मुआवजा, व्यक्तिगत सुरक्षा उपकरण (पीपीई), श्रम कानून, पीएफ, पर्यावरण संरक्षण और सीमित स्थान प्रवेश के लिए ठेकेदारों / आपूर्तिकर्ताओं को दिशा-निर्देश का पालन करेगा।

The Contractor shall follow all clause in Annexure – A, B & C like ESI, Safety Regulations and General Conditions of Contract, Workmen Compensation, Personal Protective Equipments (PPE), Labor Laws, PF, Guidelines to contractors / suppliers for environmental protection & Confined Space Entry.

#### ईएसआई/ईपीएफ योजना ESI/EPF SCHEME

कॉन्ट्रैक्टर को अपने कर्मचारियों का एम्प्लॉई स्टेट इंश्योरेंस (ESI) और एम्प्लॉई प्रोविडेंट फंड (EPF) स्कीम के तहत एनरोलमेंट पक्का करना होगा। कॉन्ट्रैक्टर को वेज पेमेंट के कन्फर्मेशन के तौर पर, कर्मचारियों के साइन किए हुए और इंजीनियर-इन-चार्ज से सर्टिफाइड, वेज-कम-मस्टर रोल का ओरिजिनल रजिस्टर दिखाना होगा।

The contractor shall ensure the enrollment of their employees under the Employees State Insurance (ESI) and Employees Provident Fund (EPF) Schemes. The contractor is required to present the original Register of Wages-cum-Muster Roll, signed by the employees and duly certified by the Engineer-in-Charge as confirmation of wage payments.

अगर कॉन्ट्रैक्टर के पास अपने ESI और EPF कोड हैं और उसने अपने कर्मचारियों को इन कोड के तहत कवर किया है, तो उन्हें महीने में पैसे भेजने के सबूत के तौर पर ओरिजिनल चालान जमा करने होंगे। इसके अलावा, कॉन्ट्रैक्टर को उस समय के कंट्रीब्यूशन रिटर्न की एक कॉपी देनी होगी ताकि यह कन्फर्म हो सके कि उनके कर्मचारी स्कीम में एनरोल हैं।

If the contractor possesses their own ESI and EPF codes and has covered their employees under these codes, they shall submit the original challans as proof of monthly remittance. Additionally, the contractor is required to provide a copy of the Contribution Return for the relevant period to confirm that their employees are enrolled in the schemes.

SI लिमिट से ज़्यादा सैलरी पाने वाले कर्मचारियों के लिए, वर्कमैन कम्पनसेशन पॉलिसी या ग्रुप पर्सनल एक्सीडेंट पॉलिसी के तहत कवरेज ज़रूरी है। डॉक्यूमेंट्री प्रूफ जमा करना होगा।

For the employees earning salaries beyond ESI limit, coverage under a Workmen Compensation Policy or Group Personal Accident Policy is required. Documentary proof shall be submitted.

11. टेंडर देने वालों को हमारी वेबसाइट [www.hoclkochi.com](http://www.hoclkochi.com) से GCC (कॉन्ट्रैक्ट की जनरल कंडीशंस) डाउनलोड करनी होगी और ज़रूरी हिस्सों को पूरी तरह समझना होगा।

The tenderers have to download the GCC (General Conditions of Contract) from our web site [www.hoclkochi.com](http://www.hoclkochi.com) and ensure a complete understanding of the relevant portions.

निविदाकर्ता के हस्ताक्षर Signature of the Tenderer :

निविदाकर्ता का नाम Name of the Tenderer :

पता Address :

स्थान Place: मोहर SEAL

दिनांक Date:

Tender Inviting Authority: M/s. Hindustan Organic Chemicals Ltd.

Name of Work: INSTALLATION OF CABLE TRAY SYSTEM FOR POND MOTOR

Contract No: HOC/ELE/W&P/7095/25

**NOTE 1: The Total quantity of procurement (1) mentioned in Bid Document indicates Lumpsum based hiring. Bidder should enter the grand total (All inclusive) as the quoted rate**

**NOTE 2: Bidder has to upload this BOQ sheet duly filled, signed and sealed in PDF format along with the financial documents sought through the GeM bid.**

Name of the Bidder/ Bidding Firm / Company	
--	--

**PRICE SCHEDULE**

**(DOMESTIC TENDERS - RATES ARE TO GIVEN IN RUPEES (INR) ONLY)**

**(This BOQ template must not be modified/replaced by the bidder and the same should be uploaded after filling the relevant columns, else the bidder is liable to be rejected for this tender. Bidders are allowed to enter the Bidder Name and Values only )**

NUMBER #	TEXT #	TEXT #	NUMBER #	TEXT #	NUMBER #	NUMBER #	TEXT	NUMBER #	NUMBER #	TEXT #	
Sl. No.	Item Description	Item Code / Make	Quantity	Units	BASIC RATE In Figures To be entered by the Bidder in Rs. P	GST in %	Service Account code ( SAC )	TOTAL AMOUNT Without Taxes in Rs. P	TOTAL AMOUNT With Taxes Rs. P	TOTAL AMOUNT In Words With Taxes	
1	2	3	4	5	7	47	49	13	14	15	
1	Supply and installation of FRP-cable tray 300 mm (W) x 100 mm (H),C section 4mm thick, 3 m length, complete, including couplers, fasteners, and all standard accessories.	S3001239	60	M				-	-		
2	Supply and installation of FRP cable tray horizontal bends, 300 mm (W) x 100 mm (H),C section 4mm thick complete with couplers, fasteners, and all standard accessories, as per specifications.	S3001240	3	NOS				-	-		
3	Supply and fabrication of M.S Supports for Cable tray system as per approved drawing, including cutting, drilling, welding,painting, surface finishing, and all necessary hardware.	S3001243	900	KG				-	-		
4	Excavation for concreting cable ladder supports up to 1.0 m depth in Soil, including backfilling and compaction after concreting, complete as per scope of work.	S3001242	11	CUM				-	-		
5	Concreting of foundation for cable Ladder supports as per approved drawing with PCC in the proportion 1:2:4 , complete as per scope of work and specifications.	S3001241	6	CUM				-	-		
<b>Total in Figures</b>								-	-		
<b>Quoted Rate in Words (With Tax)</b>											

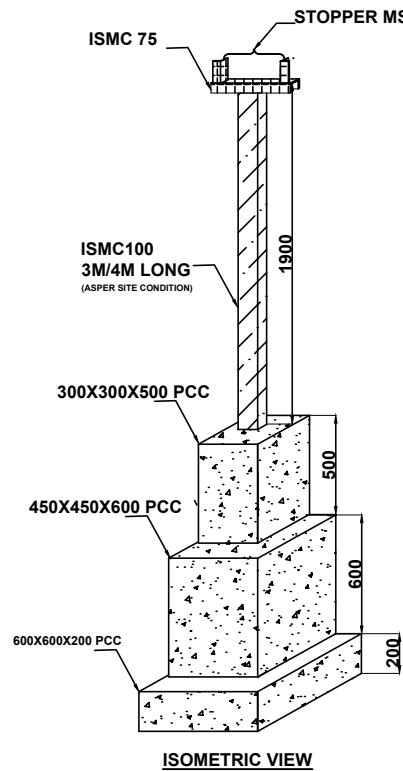

**ISOMETRIC VIEW**

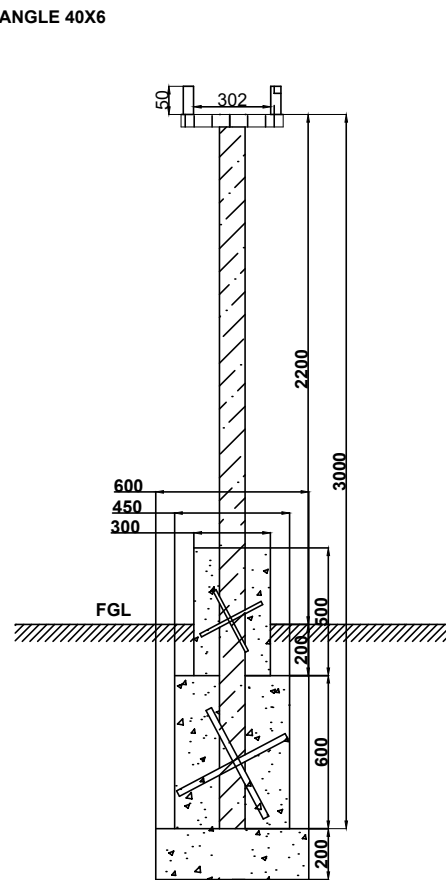

**CIVIL FOUNDATION**

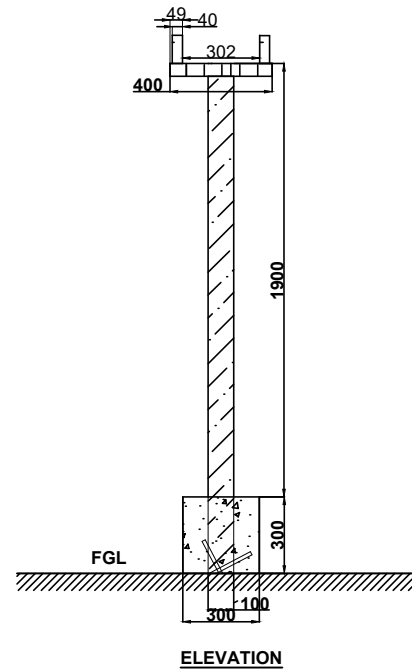

**ELEVATION**

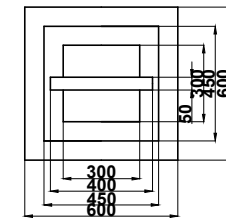

**CIVIL FOUNDATION (TOP VIEW)**

**Foundation**  
P.C.C Ratio: 1:2:4

**Acceptable makes**  
Cement: UltraTech & Malabar

**Geometry & fabrication**

**Overall Channel length:**  
3000/4000mm Asper site condition  
(2.2 m above FGL, & .8 m below FGL)

**Top mounting**  
Weld a top bracket made from ISMC 75  
400 mm in length, asper drawing  
Stopper shall be provided for the tray support  
as per the drawing

All dimensions are in mm unless otherwise specified.

DRN BY RAHUL RAJAN	PMD	HINDUSTAN ORGANIC CHEMICALS LIMITED, AMBALAMUGAL, KOCHI		
CHD BY: SUJITH PM	DPT			
APPRD BY	SCALE N T S	POND FRP CABLE TRAY SUPPORT	SW XXXXX	2
DATE - 23.12.2025			PAGE 1 OF 1	REV

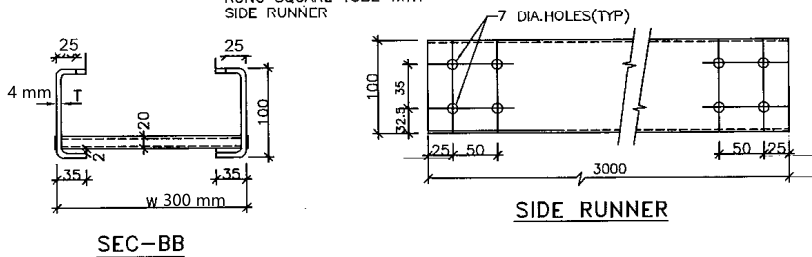
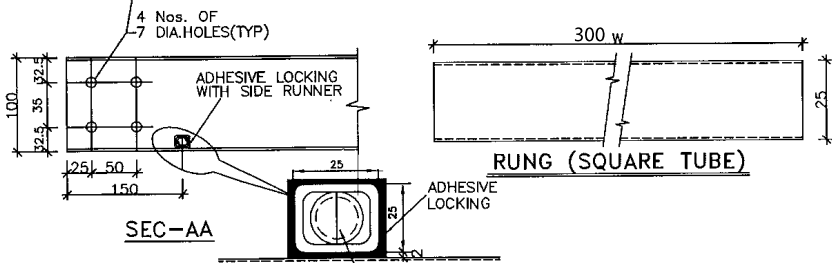
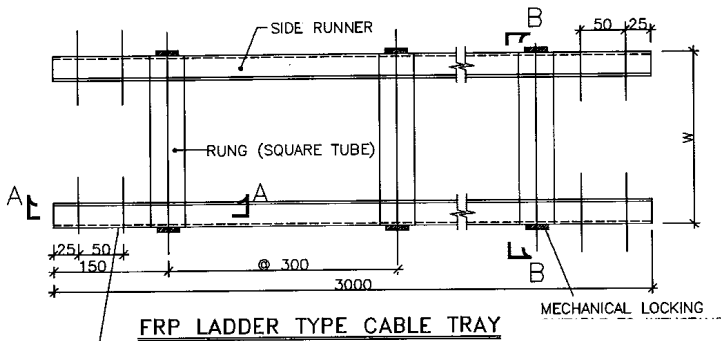

TYPICAL DETAILS OF FRP TYPE CABLE TRAYS AND ACCESSORIES

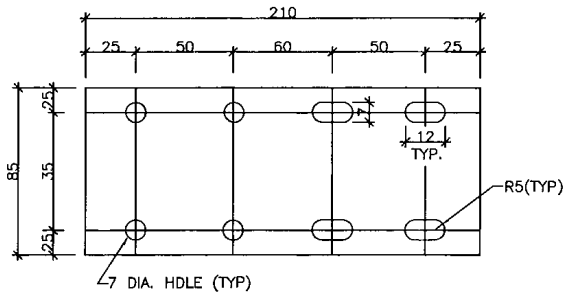

**FRP SIDE COUPLER PLATE FOR  
FRP LADDER/PERFORATED TYPE TRAYS**

QTY. REQUIRED/TRAY SECTION : 4 NOS.



QTY. REQD/TRAY SECTION  
 6A) 16 NOS. M6 BOLTS  
 B) 16 NOS. NUTS  
 C) 32 NOS. WASHERS

(2 NOS. COUPLER PLATES  
 OF 4 MM THICKNESS TO  
 BE SUPPLIED PER JOINT)

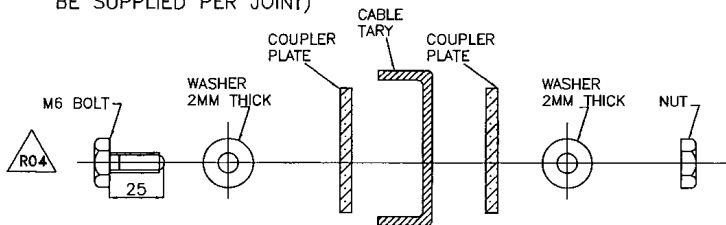

SEQUENCE OF M6 BOLT, WASHER, NUT, COUPLER PLATE & CABLE TRAY  
 FOR TYPICAL CABLE TRAY JOINT

TYPICAL DETAILS OF FRP TYPE CABLE  
 TRAYS AND ACCESSORIES