



हिंदुस्तान ऑर्गेनिक केमिकल्स लिमिटेड HINDUSTAN ORGANIC CHEMICALS LTD
(भारत सरकार का उद्यम Government of India Enterprise)
अंबलमुगल, कोची AMBALAMUGAL, COCHIN – 682 302
दूरभाष Phone: (0484) 2720911, फ़ैक्स FAX No. (0484) 2720893

OPEN E- TENDER NOTICE

HOCL Invites open e Bids for the following item.

| Sl.No. | Description of item and Tender No. | Qty (Approx) to be Supplied |
|--------|--|---|
| 1 | SPA (SOLID PHOSPHORIC ACID) CATALYST HOCL tender ref : MAT/PUR/50348/22 | 84 MT (Or to the nearest packing size) |

Tender documents may be downloaded from www.hoclindia.com or www.eprocure.gov.in

Interested parties may please get registered with NIC e-procurement portal (URL: <https://eprocure.gov.in/eprocure/app>) to participate in the tender. Tenders submitted other than through online procedure specified will not be accepted. Please visit the above sites regularly for any addendum/ corrigendum/extension before submitting the offers.

This is an open Tender and interested parties may quote in two bid system.

EARNEST MONEY DEPOSIT (EMD):- INR.1,00,000.00 for Indian Bidders.
\$1300 for Foreign Bidders

DUE DATE OF SUBMISSION : 26.09.2022 by 2.00 pm

DATE OF OPENING TENDER : 27.09.2022 by 2.00 pm

REGARDS,

B.BALACHANDRAN, GM (MATERIALS)

HINDUSTAN ORGANIC CHEMICALS LTD



हिंदुस्तानऑर्गेनिककेमिकल्सलिमिटेडHINDUSTAN ORGANIC CHEMICALS LTD
(भारतसरकारकाउद्यमA Government of India Enterprise)
अंबलमुगल,कोचीAMBALAMUGAL, COCHIN – 682 302
दूरभाषPhone: (0484) 2720911

MAT/PUR/50348/22

02.09.2022

Dear Sir,

We, Hindustan Organic Chemicals Ltd. is a Govt. of India Undertaking manufacturing Phenol & Acetone through Cumene synthesis route at its plant at Kochi, Kerala, India. Our installed capacity is 40,000 MT of Phenol, 26,000 MT Acetone & 56,000 MT Cumene. M/s.UOP is the technology supplier for the above plant. We are inviting tenders for supply of 84 MT (Or to the nearest packing size) Solid Phosphoric Acid Polymerization Catalyst for Cumene synthesis in the plant.

You may please get registered as a vendor with NIC (CPP Portal) for participating in this tender.

Tender documents are uploaded in HOCL website www.hoclindia.com and www.eprocure.gov.in

The details of the tender are as shown below.

HOCL tender ref: MAT/PUR/50348/22

Closing Date & Time for Bid submission: 26.09.2022 at 2.00 PM

Tender Opening Date & Time: 27.09.2022 at 02.00 PM

EMD : INR.1,00,000/- for Indian Bidders. For Foriegn Bidders: USD- 1300.00

You may submit your offer in **Two bid** system online before the due date and time specified. Tenders submitted other than through online procedure specified will not be accepted. Please visit the above sites regularly for any addendum/ corrigendum

Thanking you,

Yours faithfully,
For Hindustan Organic Chemicals Ltd.

B.BALACHANDRAN
GENERAL MANAGER (MATERIALS)

INDEX - TENDER NOTICE FOR THE SUPPLY OF SPA CATALYST

| | | |
|----|--|---------------------|
| 1 | Instructions for Online Bid Submission | Annexure - I |
| 2 | General instructions to the bidders for bid submission | Annexure-II |
| 3 | Parameters of the Catalyst Offered | Annexure III |
| 4 | Specification of Benzene used by us in the Manufacturing Process | Annexure-IV |
| 5 | Required Cumene Specification | Annexure-V |
| 6 | Brief Process Description/Cumene Reactor Parameters | Annexure-VI |
| 7 | Eligibility criteria for participating in the bid | Annexure-VII |
| 8 | Terms and conditions of the tender for supply of SPA Catalyst | Annexure-VIII |
| 9 | Technical bid format | Annexure-IX |
| 10 | Price bid format | Annexure-X |
| 11 | Commercial Term Format | Annexure XI-A, B& C |
| 12 | Integrity Pact Format | Annexure-XII |
| 13 | Bid Security Declaration | Annexure- XIII |
| 14 | Compliance To Clause W.R.T Mandatory Registration OfVendors From Countries Sharing Land Border With India,With DPIIT | Annexure-XIV |

ऑनलाइन प्रस्तुतीकरणकेलिएअनुदेश Instructions for Online Submission

बोलीदाताओंकोअपनीबोलियोंकीसॉफ्टप्रतियाँमान्यडिजिटलसिग्नेचरसर्टिफिकेटकाउपयोगकरकेसीपीपीपोर्टलपरइलेक्ट्रॉनिकमाध्यमसेजमाकरनीहै।नीचेदिएगएनिर्देशसीपीपीपोर्टलपरपंजीकरणकरनेमेंबोलीलगानेवालोंकीसहायताकरने,उनकीबोलियोंकोआवश्यकताओंकेअनुसारतैयारकरनेऔरअपनीबोलियोंकोसीपीपीपोर्टलपरऑनलाइनजमाकरनेकेलिएहैं।

The bidders are required to submit soft copies of their bids electronically on the CPP Portal, using valid Digital Signature Certificates. The instructions given below are meant to assist the bidders in registering on the CPP Portal, prepare their bids in accordance with the requirements and submitting their bids online on the CPP Portal.

सीपीपीपोर्टलपरऑनलाइनबोलियांप्रस्तुतकरनेकेलिएउपयोगीजानकारी:

<https://eprocure.gov.in/eprocure/app> परप्राप्तकीजासकतीहै।

information useful for submitting online bids on the CPP Portal may be obtained at:
<https://eprocure.gov.in/eprocure/app>.

पंजीकरणREGISTRATION

1. बोलीदाताओंकोसीपीपीपोर्टलपर"**ऑनलाइनबोलीनामांकन**"लिंकपरक्लिककरकेकेंद्रीयसार्वजनिकखरीदपोर्टलकेई-प्रोक्योरमेंटमॉड्यूल) URL: <https://eprocure.gov.in/eprocure/app>)परनामांकनकरनाआवश्यकहैजोनिःशुल्कहै।
Bidders are required to enroll on the e-Procurement module of the Central Public Procurement Portal (URL: <https://eprocure.gov.in/eprocure/app>) by clicking on the link "Online bidder Enrollment" on the CPP Portal which is free of charge.
2. नामांकनप्रक्रियाकेभागकेरूपमें,
बोलीदाताओंकोएकविशिष्टउपयोगकर्तानामचुननाहोगाऔरउनकेखातोंकेलिएएकपासवर्डनिर्दिष्टकरनाहोगा।
As part of the enrolment process, the bidders will be required to choose a unique username and assign a password for their accounts.
3. बोलीदाताओंकोसलाहदीजातीहैकिवेपंजीकरणप्रक्रियाकेरूपमेंअपनावैधईमेलपताऔरमोबाइलनंबरपंजीकृतकरें।इनकाउपयोगसीपीपीपोर्टलकेकिसीभीसंचारकेलिएकियाजाएगा।
Bidders are advised to register their valid email address and mobile numbers as part of the registration process. These would be used for any communication from the CPP Portal.
4. नामांकनकेबाद, बोलीदाताओंकोअपनेप्रोफाइलकेसाथसीसीएंडडिया(जैसेSify / nCode / eMudhraआदि)द्वारामान्यताप्राप्तकिसीभीप्रमाणनप्राधिकरणद्वाराजारीकिएगएवैधडिजिटलहस्ताक्षरप्रमाणपत्र) डीएससी ()मुख्यउपयोगपरहस्ताक्षरकरनेकेसाथकक्षाIII प्रमाणपत्र (कोपंजीकृतकरनेकीआवश्यकताहोगी)।
Upon enrolment, the bidders will be required to register their valid Digital Signature Certificate (Class III Certificates with signing key usage) issued by any Certifying Authority recognized by CCA India (e.g. Sify / nCode / eMudhra etc.), with their profile.
5. बोलीदाताद्वाराकेवलएकवैधडीएससीकोपंजीकृतकरनाचाहिए।कृपयाध्यानदेंकिबोलीदातायहसुनिश्चितकरनेकेलिएज़िम्मेदारहैंकिवेअपनेडीएससीकोदूसरोंकोउधारनदें, जिससेइसकादुरुपयोगहोसकताहै।
Only one valid DSC should be registered by a bidder. Please note that the bidders are responsible to ensure that they do not lend their DSC's to others which may lead to misuse

6. बोलीदाता तब अपनी यूजर आईडी / पासवर्ड और डीएससी / ई-टोकन के पासवर्ड को दर्ज करके सुरक्षित लॉग-इन के माध्यम से साइट पर जा सकता है।
Bidder then logs in to the site through the secured log-in by entering their user ID / password and the password of the DSC / e-Token.

निविदा दस्तावेजों के लिए खोज SEARCHING FOR TENDER DOCUMENTS

1. सीपीपी पोर्टल में विभिन्न खोज विकल्प बनाए गए हैं, जिससे बोलीदाताओं को कई मापदंडों द्वारा सक्रिय निविदाएं खोजने में सुविधा हो। इन मापदंडों में टेंडर आईडी, संगठन का नाम, स्थान, दिनांक, मूल्य आदि शामिल हो सकते हैं। निविदाओं के लिए उन्नत खोज का एक विकल्प भी है, जिसमें बोलीदाता सीपीपी पोर्टल पर प्रकाशित निविदा के लिए खोज करने के लिए एक ई-खोज मापदंडों जैसे कि संगठन का नाम, अनुबंध का प्रारूप, स्थान, दिनांक, अन्य कीवर्ड आदि जोड़ सकते हैं।
There are various search options built in the CPP Portal, to facilitate bidders to search active tenders by several parameters. These parameters could include Tender ID, Organization Name, Location, Date, Value, etc. There is also an option of advanced search for tenders, wherein the bidders may combine a number of search parameters such as Organization Name, Form of Contract, Location, Date, Other keywords etc. to search for a tender published on the CPP Portal.
2. एक बार बोलीदाताओं ने उन निविदाओं का चयन कर लिया है जिनमें वे रुचि रखते हैं, वे आवश्यक दस्तावेज / निविदा कार्यक्रम डाउनलोड कर सकते हैं। इन निविदाओं को संबंधित "मेटेंडर" फ़ोल्डर में ले जाया जा सकता है। यह सीपीपी पोर्टल को एसएमएस / ई-मेल के माध्यम से बोली लगाने वालों को यदि निविदा दस्तावेज में कोई भी शुद्धि पत्र जारी किया गया, सूचित करने में सक्षम करेगा।
Once the bidders have selected the tenders they are interested in, they may download the required documents / tender schedules. These tenders can be moved to the respective 'My Tenders' folder. This would enable the CPP Portal to intimate the bidders through SMS / e-mail in case there is any corrigendum issued to the tender document.
3. बोलीदाता को प्रत्येक निविदा को सौंपी गई अद्वितीय निविदा आईडी को नोट करना चाहिए, यदि वे हेल्पडेस्क से कोई स्पष्टीकरण / सहायता प्राप्त करना चाहते हैं।
The bidder should make a note of the unique Tender ID assigned to each tender, in case they want to obtain any clarification / help from the Helpdesk.

बोली की तैयारी PREPARATION OF BIDS

1. बोलीदाता को अपनी बोलियां जमा करने से पहले निविदा दस्तावेज पर प्रकाशित किसी भी शुद्धि पत्र पर विचार करना चाहिए।
Bidder should take into account any corrigendum published on the tender document before submitting their bids.
2. बोली के साथ प्रस्तुत किए जाने वाले आवश्यक दस्तावेजों को समझने के लिए कृपया निविदा विज्ञापन और निविदा दस्तावेज को ध्यान से पढ़ें। कृपया उन कवरों की संख्या पर ध्यान दें जिनमें बोली दस्तावेज जमा करने हैं, दस्तावेजों की संख्या - प्रत्येक दस्तावेज के नाम और सामग्री सहित जिन्हें प्रस्तुत करने की आवश्यकता है। इनमें से किसी भी विचलन से बोली की अस्वीकृति हो सकती है।
Please go through the tender advertisement and the tender document carefully to understand the documents required to be submitted as part of the bid. Please note the number of covers in which the bid documents have to be submitted, the number of

documents - including the names and content of each of the document that need to be submitted. Any deviations from these may lead to rejection of the bid.

3. बोलीदाताको, पहलेहीनिविदादस्तावेज / अनुसूचीमेंदर्शाएअनुसारप्रस्तुतकिएजानेवालेबोलीदस्तावेजतैयारकरनाचाहिएऔरआमतौरपर, वेपीडीएफ/एक्सएलएस/आरएआर/डीडब्ल्यूएफ / जेपीजीप्रारूपोंमेंहोसकतेहैं।बोलीदस्तावेजोंकोकालेऔरसफेदविकल्पकेसाथ100डीपीआईकेसाथस्कैनकियाजासकताहैजोस्कैनकिएगएदस्तावेजकेआकारकोकमकरनेमेंमददकरताहै।
Bidder, in advance, should get ready the bid documents to be submitted as indicated in the tender document / schedule and generally, they can be in PDF / XLS / RAR / DWF/JPG formats. Bid documents may be scanned with 100 dpi with black and white option which helps in reducing size of the scanned document.
4. मानकदस्तावेजोंजिनकोप्रत्येकबोलीकेसाथप्रस्तुतकरनेकीआवश्यकताहोतीहै,केएकजैसेसेटकोअपलोडकरनेमेंलगनेवालेसमयऔरप्रयाससेबचनेकेलिए, (ऐसेमानकदस्तावेजों) जैसेपैनकार्डप्रति, वार्षिकरिपोर्ट, लेखापरीक्षाप्रमाणपत्रआदि (कोअपलोडकरनेकाप्रावधानबोलीदाताओंकोप्रदानकियागयाहै।बोलीदाताइसतरहकेदस्तावेजअपलोडकरनेकेलिएउनकोउपलब्ध" मेरास्थान "या'अन्यमहत्वपूर्णदस्तावेज' स्थानकाउपयोगकरसकतेहैं।येदस्तावेजसीधेबोलीलगातेसमय" मेरास्थान "सेप्रस्तुतकियाजासकताहै, औरबार-बारअपलोडकरनेकीआवश्यकतानहींहै।इससेबोलीप्रस्तुतकरनेकीप्रक्रियाकेलिएआवश्यकसमयमेंकमीआएगी।
To avoid the time and effort required in uploading the same set of standard documents which are required to be submitted as a part of every bid, a provision of uploading such standard documents (e.g. PAN card copy, annual reports, auditor certificates etc.) has been provided to the bidders. Bidders can use "My Space" or "Other Important Documents" area available to them to upload such documents. These documents may be directly submitted from the "My Space" area while submitting a bid, and need not be uploaded again and again. This will lead to a reduction in the time required for bid submission process.

नोट: मईडोक्यूमेंडस्थानकेवलअपलोडकरनेकीप्रक्रियाकोआसानबनानेकेलिएबोलीदाताओंकोदियागयाएकसंग्रहस्थानहै।यदिबोलीदातानेमईडोक्यूमेंडस्थानमेंअपनेदस्तावेजअपलोडकिएहैं, तोयहइनदस्तावेजोंकोतकनीकीबोलीकेहिस्सेकेरूपमेंस्वयंसुनिश्चितनहींकरसकताहै।

Note: My Documents space is only a repository given to the Bidders to ease the uploading process. If Bidder has uploaded his Documents in My Documents space, this does not automatically ensure these Documents being part of Technical Bid.

बोलीकीप्रस्तुतिSUBMISSION OF BIDS

1. बोलीदाताकोबोलीजमाकरनेकेलिएपहलेसेसाइटपरलॉगइनकरनाचाहिएताकिवेबोलीसमयपरअपलोडकरसकें।यानिबोलीप्रस्तुतिसमयपरयाउससेपहलेकरसकतेहैं।बोलीदाताअन्यविषयोंकेकारणकिसीभीदेरीकेलिएजिम्मेदारहोगा।
Bidder should log into the site well in advance for bid submission so that they can upload the bid in time i.e. on or before the bid submission time. Bidder will be responsible for any delay due to other issues.
2. बोलीदाताकोडिजिटलीहस्ताक्षरकरनाहोगाऔरआवश्यकबोलीदस्तावेजोंकोएक-एककरकेअपलोडकरनाहोगाजैसाकिनिविदादस्तावेजमेंदर्शायागयाहै।
The bidder has to digitally sign and upload the required bid documents one by one as indicated in the tender document.

- 3 बोलीदाताकोयथालागूनिविदाशुल्क / ईएमडीकेभुगतानकेलिए" ऑफ़लाइन " भुगतानविकल्पकाचयनकरनाहैऔरलिखतकेविवरणदर्जकरनाहै। Bidder has to select the payment option as "offline" to pay the tender fee / EMD as applicable and enter details of the instrument.
- 4 बोलीदाताकोनिविदादस्तावेजमेंनिर्दिष्टनिर्देशोंकेअनुसारईएमडीतैयारकरनाचाहिए।मूलप्रतिकोबोलीजमाकरने कीअंतिमतिथितकयानिनिविदादस्तावेजोंमेंनिर्दिष्टअनुसार, डाक /कूरियरद्वारा / संबंधितअधिकारीकोव्यक्तिगतरूपसेदियाजानाचाहिए।भौतिकरूपसेभेजेगएडीडी/किसीभीअन्यस्वीकृतलिखत काविवरण, स्कैनकीगयीकॉपीमेंउपलब्धविवरणऔरबोलीजमाकरनेकेसमयदर्जकिएगएडेटाकेसाथमेलखानाचाहिए।अन्यथा अपलोडकीगईबोलीअस्वीकारकरदीजाएगी। Bidder should prepare the EMD as per the instructions specified in the tender document. The original should be posted/couriered/given in person to the concerned official, latest by the last date of bid submission or as specified in the tender documents. The details of the DD/any other accepted instrument, physically sent, should tally with the details available in the scanned copy and the data entered during bid submission time. Otherwise the uploaded bid will be rejected.
- 5 बोलीदाताओंसेयहनोटकरनेकाअनुरोधहैकिउनकोप्रदानकीगईप्रारूपमेंअपनीवित्तीयबोलियांअवश्यरूपसेप्रस्तुत करनाचाहिएऔरकोईअन्यप्रारूपस्वीकार्यनहै।यदिनिविदाबोलीकेसाथमूल्यबोलीकोएकमानकबीओक्यू) BoQ) प्रारूपकेरूपमेंदियागयाहै, तोवहीडाउनलोडकियाजानाहैऔरसभीबोलीदाताओंद्वाराभराजानाहै।बोलीदाताओंकोबीओक्यू) BoQ) फ़ाइलडाउनलोडकरना, उसेखोनाऔरअपनेसंबंधितवित्तीयभावऔरअन्यविवरणों) जैसेबोलीदाताकानाम (केसाथसफेदरंग) असुरक्षित (स्थानोंकोपूराकरनेकीआवश्यकताहोतीहै।किसीभीअन्यस्थानोंमेंबदलावनहींकरनाचाहिए।एकबारविवरणपूरा होजानेकेबाद, बोलीदाताकोफ़ाइलसेवकरकेनामबदलेबिनाइसेऑनलाइनप्रस्तुतकरनाचाहिए।यदिबीओक्यू) BoQ)फ़ाइलकोबोलीदाताद्वारासंशोधितपायाजाताहै, तोबोलीअस्वीकारकरदीजाएगी। Bidders are requested to note that they should necessarily submit their financial bids in the format provided and no other format is acceptable. If the price bid has been given as a standard BoQ format with the tender document, then the same is to be downloaded and to be filled by all the bidders. Bidders are required to download the BoQ file, open it and complete the white coloured (unprotected) cells with their respective financial quotes and other details (such as name of the bidder). No other cells should be changed. Once the details have been completed, the bidder should save it and submit it online, without changing the filename. If the BoQ file is found to be modified by the bidder, the bid will be rejected.
- 6 सर्वरसमय) जिसेबोलीदाताओंकेडैशबोर्डपरप्रदर्शितकियाजाताहै (कोबोलीदाताओंद्वाराबोलियांप्रस्तुत करनेकेलिएसमयसीमाकोसंदर्भितकरने,बोलियांखोलनेआदिकेलिएमानकस मयमानाजाएगा।बोलीप्रस्तुतिकेदौरानबोलीदाताओंकोइससमयकापालनकरनाचाहिए। The server time (which is displayed on the bidders' dashboard) will be considered as the standard time for referencing the deadlines for submission of the bids by the bidders, opening of bids etc. The bidders should follow this time during bid submission.
- 7 डेटाकीगोपनीयतासुनिश्चितकरनेकेलिएबोलीदाताओंद्वाराप्रस्तुतकिएजारहेसभीदस्तावेजोंकोपीकेआईकूटलेख न) एन्क्रिप्शन (तकनीकोंकाउपयोगकरकेकूट) एन्क्रिप्ट (कियाजाएगा।दर्जकियागयाडेटाअनधिकृतव्यक्तियोंद्वाराबोलीखोलनेकेसमयतकनहींदेखाजासकताहै।बोलियों कीगोपनीयतासुरक्षितसॉफ्टवेयर128बिटएन्क्रिप्शनप्रौद्योगिकीकाउपयोगकरकेबनाएरखीजातीहै।संवेदनशील

क्षेत्रों का डेटा संग्रह एन्क्रिप्शन किया जाता है। सर्वर पर अपलोड किए गए कोई भी बोली दस्तावेज सिस्टम द्वारा जनित सममित कुंजी का उपयोग करके सममित एन्क्रिप्शन के अधीन है। इसके अलावा, इस कुंजी को क्रेताओं /

बोली खोलने वालों की सार्वजनिक कुंजी का उपयोग करके असममित एन्क्रिप्शन के अधीन किया जाता है। कुल मिलाकर, अपलोड किए गए निविदा दस्तावेज प्राधिकृत बोली खोलने वालों द्वारा निविदा खोलने के बाद ही पठनीय हो जाते हैं।

All the documents being submitted by the bidders would be encrypted using PKI encryption techniques to ensure the secrecy of the data. The data entered cannot be viewed by unauthorized persons until the time of bid opening. The confidentiality of the bids is maintained using the secured Socket Layer 128 bit encryption technology. Data storage encryption of sensitive fields is done. Any bid document that is uploaded to the server is subjected to symmetric encryption using a system generated symmetric key. Further this key is subjected to asymmetric encryption using buyers/bid opener's public keys. Overall, the uploaded tender documents become readable only after the tender opening by the authorized bid openers.

- 8 अपलोड किए गए एंटेडर दस्तावेज अधिकृत बोली सलामी बल्लेबाजों द्वारा निविदा खोलने के बाद ही पठनीय हो जाते हैं।
The uploaded tender documents become readable only after the tender opening by the authorized bid openers.

- 9 बोलियों के सफल और समय पर प्रस्तुतीकरण) यानी पोर्टल में " फ्रीज बिड सबमिशन " पर क्लिक करने के बाद, पोर्टल एक सफल बोली प्रस्तुत करने का संदेश देगा और बोली संख्या तथा अन्य सभी प्रासंगिक विवरणों के साथ बोली प्रस्तुत करने की तिथि और समय के साथ एक बोली सारांश प्रदर्शित किया जाएगा।

Upon the successful and timely submission of bids (i.e. after Clicking "Freeze Bid Submission" in the portal), the portal will give a successful bid submission message & a bid summary will be displayed with the bid no. and the date & time of submission of the bid with all other relevant details.

- 10 बोली सारांश का प्रिंट किया जाना है और बोली प्रस्तुत करने की पावती के रूप में रखा जाना है। इस पावती का उपयोग किसी भी बोली खुलाव बैठक के लिए प्रवेश पास के रूप में किया जा सकता है।

The bid summary has to be printed and kept as an acknowledgement of the submission of the bid. This acknowledgement may be used as an entry pass for any bid opening meetings.

बोली दाताओं को सहायता ASSISTANCE TO BIDDERS

1. निविदा दस्तावेज और उसमें निहित नियमों और शर्तों से संबंधित किसी भी प्रश्न को निविदा के लिए निविदा आमंत्रण प्राधिकरण को या निविदा में उल्लेखित संबंधित संपर्क व्यक्ति को संबोधित किया जाना चाहिए।

Any queries relating to the tender document and the terms and conditions contained therein should be addressed to the Tender Inviting Authority for a tender or the relevant contact person indicated in the tender.

2. ऑनलाइन बोली प्रस्तुत करने की प्रक्रिया से संबंधित कोई भी प्रश्न या सामान्य रूप से सीपीपी पोर्टल से संबंधित प्रश्न 24 x 7 सीपीपी पोर्टल हेल्पडेस्क को निर्देशित किए जा सकते हैं।

Any queries relating to the process of online bid submission or queries relating to CPP Portal in general may be directed to the 24x7 CPP Portal Helpdesk.

ANNEXURE- II**GENERAL INSTRUCTIONS TO BIDDERS FOR BID SUBMISSION**

Please submit your e-bids under the two bid system conforming to the specifications and the terms and conditions attached as per instructions given below:-

1. HOCL has entered into an Agreement with **NIC** for e-procurement through their portal www.eprocure.gov.in. Quotations shall be submitted online on or before the due date and time of closing the tender. The Techno commercial bid containing the Technical specification of the Products and Proof of satisfactorily meeting the Eligibility Criteria and all commercial terms should be uploaded as per instructions given in Annexures. The Price bid should be submitted in price bid format given.
2. Techno commercial bid shall be opened electronically on specified date and time given in NIT. Bidders can witness the electronic opening of bid .The date and time of opening of the price bids will be intimated to the technically qualified bidders after evaluation of the Technical bids via email alerts through the valid emails confirmed.
3. The bid shall contain as integral part of the same the following compliance statement: “We have read, understood and accepted the terms and conditions of purchase and related documents forming part of this enquiry and agree to supply the goods in compliance with the same.”
4. The bids shall be neatly typed in English language with pages consecutively numbered and shall be signed on all pages by authorized persons. Bids shall be free from over writing and all corrections shall be duly attested by the bidder.
5. Bidders should carefully study the documents of this enquiry. All terms and conditions set out there in the enquiry shall be binding on the bidders unless conflicting with any terms and conditions expressly stated by HOCL while accepting any bid, in the event of such acceptance.
6. HOCL reserves the right, without assigning any reason whatsoever, to accept or reject any or all bids in part or in full or cancel this enquiry.
7. HOCL reserves the right to extend without giving any reason(s) the closing date/time of the enquiry.
8. Bids shall be valid for a minimum of 120 days from the due date for receipt and opening of the bids.
10. Purchase Preference to Central Public Sector Enterprises of Govt. of India and MSME’s shall be as per Govt. of India policy in vogue.

PARAMETERS OF THE CATALYST OFFERED

Solid Phosphoric Acid Polymerization catalyst for Cumene synthesis.

Technical specification of the catalyst should include the following:

- i. Guaranteed Cumene yield per M3 of catalyst offered by you.
- ii. Guaranteed Cumene yield per MT of Catalyst offered by you.
- iii. The Reactor Liquid Hourly Space Velocity (LHSV).
- iv. Reactor operating pressure and temperature.
- v. Catalyst shape & size.
- vi. Specified ratio of propylene to propane and propylene to Benzene.
- vii. Hydration level.
- viii. Propylene conversion rate.
- ix. Selectivity to Cumene/by-product formation.
- x. Density of catalyst offered.
- xi. Crushing Strength.

ANNEXURE-IV**SPECIFICATIONS OF BENZENE USED BY US IN THE MANUFACTURING PROCESS**

| Sl.No. | Parameters | Specifications |
|---------------|---|-----------------------|
| 1. | Colour (Pt-Co Scale), max. | 15 |
| 2. | Relative Density at 15°C/15°C | 0.8790-0.8860 |
| 3. | Solidification Point(°C) on dry basis, min. | 5.40 |
| 4. | Distillation Range (°C) (including 80.1°C), max. | 1.0 |
| 5. | Acid wash test, max. | No.1 |
| 6. | Purity by GC(wt %), min. | 99.90 |
| 7. | Non-aromatics by GC(wt.ppm), max. | 700 |
| 8. | Heavy Aromatics by GC (wt.ppm), max. (including Toluene 150 ppm max.) (Ref.ASTM D5871-07/IS:534-92 Specification) | 300 |

REQUIRED CUMENE SPECIFICATION

| Sl.No. | Parameters | Specifications |
|--------|--|--|
| 1 | Appearance | Clear liquid, free of sediment or Haze @ 18.3 to 25.6 Deg.c |
| 2 | Colour (HU), max. | 15 |
| 3 | Purity by GC(Wt.%), min. | 99.92 |
| 4 | Other impurities by GC (Wt.%), max. | 0.08 |
| 5 | Bromine Index, max. | 100 |
| 6 | Phenols (ppm),max. (Ref.ASTM D-4077-07) | 5 |

BRIEF PROCESS DISCRIPTION /CUMENE REACTOR PARAMETERS

The reactor is an up flow reactor with single feed point at bottom, having four beds with equal quantity of catalyst loaded in each bed. The reactor operating temperature is 185 to 210 Degree centigrade at the reactor inlet and 220 to 243 degree centigrade at the reactor outlet. The normal operating pressure is 34Kg/cm2 (g)/500 psig.

A mixture of Propylene, Propane & Benzene in the ratio 1:2:8 is converted to Cumene in the presence of SPA catalyst. By multistage fractionation technique, the Cumene and heavy aromatics are separated. The un-reacted Benzene and part of propane are recycled back to the reactor and Excess propane is removed from the system.

The propylene feed concentration is maintained between 70 to 85 %

The catalyst in the reactor is filled in 4 equal beds of 21 M³ each totaling 84 M³.

HOCL's annual production of Cumene is 56,000.00 MT and replacement of catalyst is done generally once in two years. **Hence the yield to be guaranteed should be 1,12,000.00 MT per charge of the catalyst which is 84 M³. The minimum guaranteed yield under the above condition works out to 1,333 MT/per M³ (1,12,000 MT for 84 M³) of Catalyst loaded.**

The current LHSV rate is 0.80 to 1.00 per Hr. **The supplier also need to guarantee that there will be no fluidization under the above operating conditions/parameters, if the catalyst offered by the party is having less density.**

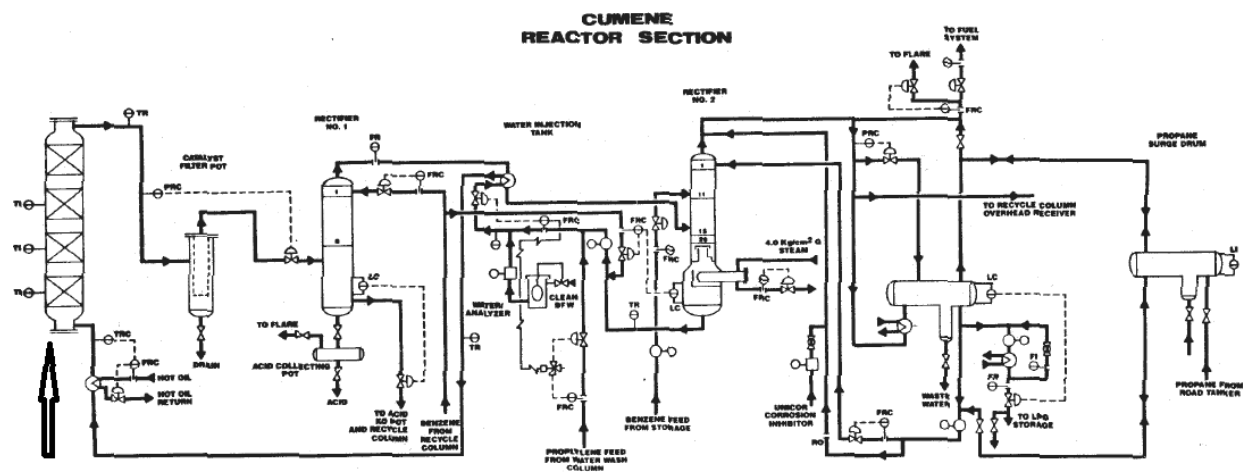

**REACTOR IS UP FLOW
WITH SINGLE FEED
POINT AT BOTTOM**

ANNEXURE - VII**ELIGIBILITY CRITERIA FOR PARTICIPATING IN THE BID.****Offer of bidders who satisfy the following Eligibility Criteria only will be considered.**

- 1) The bidder should be a manufacturer or bonafide distributor/dealer of the manufacturer of the Catalysts.
- 2) The bidder should have supplied at least 160 MT of the catalyst during the past 3 year period to reputed manufacturers of Cumene using fixed bed reactors and having a minimum 1,00,000 TPA manufacturing capacity. Please enclose purchase order copies for the supply of the same from reputed manufacturers.
- 3) Restriction on procurement from Bidder who shares the land border with India
 - a) Any bidder from a country which shares a land border with India will be eligible to bid, only if the bidder is registered with the Department for promotion of Industry and Internal Trade (DPIIT). (Pl. refer office Memorandum no. 6/18/2019-PPD dated 23rd July 2020)Such bidders should submit the valid copy of registration certificate along with tender. However the said requirement of registration will not be applicable to bidders from those country to which Govt. of India has extended lines of credit or in which Govt. of India is engaged in development of projects. Bidders may appraise themselves of the updated lists of such countries available in the website of Ministry of External Affairs.
 - b) All Bidders shall furnish compliance certificate with respect to above clause as per the format in Annexure XIV along with the bid.
- 4) Please enclose performance evaluation certificate from the above manufacturers of Cumene indicating their manufacturing capacity and yield obtained for the Catalyst supplied by you for the last 3 year period.
- 5) You must guarantee a minimum yield of 1,333 MT Cumene per M³ of catalyst. Corporate Guarantee valid for two years should be provided along with the technical bid documents.
- 6) You should be able to deliver the catalyst within minimum period after the placement of the order on you.
- 7) The existing approved suppliers of HOCL for the above catalyst are exempted from furnishing details on clause 1 & 2 of Eligibility criteria. However in case if the existing suppliers are offering Catalysts of different specification than which is used and proven at HOCL, they should provide performance Certificate from the current user/ users of the product being offered. They should provide details of the Plant/Plants where the Product is currently used along with the quantity charged per reactor (Both Weight and Volume) and the yield as on date as well as the yield committed by the Party. Technical offers submitted by existing suppliers will be evaluated considering the past performance of the catalysts supplied by them to HOCL.
- 8) Bidders may confirm adherence to all the above points in your technical bid with documentary evidence.

ANNEXURE-VIII**TERMS AND CONDITIONS FOR SUPPLY OF SPA CATALYST**

1. **PRICE**:- The rate quoted should be on CIF KOCHI per MT basis for foreign suppliers and for Indian suppliers, rates shall be quoted in Indian Rupees per MT on delivered basis.
2. **PACKING**:- Supply of Catalysts should be in damp proof M.S. containers (Approx. 200 Kgnett) and in Seaworthy export packing.
3. **QUANTITY**:- 84 MT approximately assuming that the specific gravity of the offered catalyst is 1.0. (HOCL requirement is 84 Cubic Meter of Catalyst).
4. **SUBMISSION OF BIDS** : Bids shall be uploaded as per the instructions given in Annexure II
5. **DELIVERY**: Foreign suppliers shall dispatch the full ordered quantity on CIF basis. Indian suppliers may arrange the supply on delivered basis at HOCL Ambalamugal. You may confirm the minimum delivery period required for the supply from the date of placement of order.
6. **VALIDITY**: - Validity of the offer should be **120 days** from the due date of Tender.
7. **RIGHT TO REJECT A BID**: HOCL reserves the right to reject any bid due to reasons such as (a) Vendor not following above bidding procedures (b) Vendor not being technically acceptable to HOCL (c) Not submitting EMD with the techno commercial bid or EMD paid being lesser than the stipulated amount (d) Vendor not agreeing with the general conditions of the tender (e) Not enclosing any particular documents asked for (f) Any other valid reason.(Please refer Point No.7 in Annexure VII)
8. **EARNEST MONEY DEPOSIT** :
Bid shall be accompanied with a refundable EMD of Rs.1,00,000/- or USD 1300.00 along with the technical bid. EMD may be submitted in the form of NEFT / RTGS/ to Hindustan Organic Chemicals Ltd., through our banker **M/s Central Bank of India ,Thripunithura Branch, A/C No. 3580607136 , IFS Code:CBIN0284515**. EMD may also be submitted by way of Bank Guarantee from any scheduled banks.Details of bank transfer should be indicated in your offer. EMD of the successful tender may be adjusted against the security Deposit payable.
EMD of a tenderer shall be forfeited if he withdraws or amends his tender or impairs or derogates from the tender in any respect within the validity period of the tender.
9. **PAYMENT TERMS**:- Payment terms shall be through irrevocable L/C against dispatch documents and with interest free credit for 90 days period. If anybody offers a lesser credit period, necessary loading will be done based on the prevailing SBI PLR to make all the offers at par.

10. **COUNTRY OF ORIGIN** : At Seller's option – Please refer Point No 3 in Annexure VII
11. **MANUFACTURERS TEST CERTIFICATE/GUARANTEE CERTIFICATE:-** You must enclose the manufacturers test certificate of the item & Guarantee certificate for the specific yield for the product.
12. Tenders are to be uploaded in English language only.
13. For comparison of tenders, the Currency of tendered price will be converted to Indian rupees based on State Bank of India TT selling exchange rates applicable on the close of the previous working day of price bid opening date.

14. LIQUIDATED DAMAGES:

In the event of the supplier's failure to deliver the goods by the dates specified in the contract, the purchaser may without prejudice to his any other rights hereunder, recover from the supplier liquidated damages @ 0.5 percent per week of delay of the contract price of the undelivered goods, subject to a maximum of 5 %.

15. **SECURITY DEPOSIT/PBG:** In the event of placement of order , the supplier shall furnish a security deposit/PBG of 3% of order value within 21 days of placement of order. This may be submitted in the form of a Performance Bank Guarantee from a Scheduled bank or by online payment. SD will be forfeited in the event of a breach of any of the terms of the contract by the supplier. SD should remain valid for a period of 60 days beyond the date of completion of all contractual obligation of supplier including guarantee/warrantee obligation.

16. DOCUMENTATION:-

I. Foreign Sellers to provide following documents to the Bank within 21 days of B/L date.

- (a) Bill of Lading corresponding to the quantity loaded – 2 originals and 3 non-negotiable.
- (b) Certificate of Origin– 1 original and 2 copies.
- (c) Certificate of analysis/quality – 1 original and 2 copies
- (d) Certificate of Guarantee for yield of Cumene per MT of catalyst consumed
- (e) Packing slip – 3 copies
- (f) Commercial Invoice for the catalyst supplied. – 2 Original and 3 copies
- (g) Any other documents or additional copies required as per LC conditions.

One set of copies of above documents to be mailed as well as couriered to HOCL immediately on dispatch of goods.

Domestic suppliers may submit relevant documents pertaining to domestic transactions.

17. **OPENING OF BIDS** : Techno commercial bids will be opened electronically at **2.00 pm on 27.09.2022**. HOCL, after evaluation of the techno commercial bids, will subsequently inform all those technically acceptable vendors regarding the date and time of opening of the price bids.

18. Note : The requirement will also be floated through GeM portal and order will be finalised on the most competitive offer among the technically accepted offer received against both the portal.
19. **JURISDICTION**: All questions, disputes or differences arising under or in connection with this contract shall be subject to the exclusive jurisdiction of the courts in Ernakulam, Kerala, India only:
- a) When the contract is with domestic supplier, the applicable arbitration procedure will be as per Indian Arbitration & Conciliation Act, 1996 or any statutory modifications or reenactment/amendment from time to time and the rules made there under and for the time being in force shall apply to the arbitration proceedings.
 - b) When the contract is with foreign supplier, the supplier has the option to choose either Indian arbitration and Conciliation Act, 1996 or arbitration in accordance with the provision of UNCITRAL (United Nations Commission on International Trade Law Arbitration) Arbitration Rules.
20. **INTEGRITY PACT**: Bidder is required to sign the Integrity Pact with HOCL as per format & terms and conditions enclosed with tender in Annexure-XII. This document is essential and binding. In case a bidder does not sign & submit the Integrity Pact along with bid documents, his bid shall be liable for rejection.

TECHNICAL BID FORMAT

Techno commercial Bid should contain the following details which must be uploaded in the NIC website in pdf format :

- 1.Your covering letter of the offer on your company letter head.
- 2.If you are the authorized distributor of Manufacturer of Catalyst, Authorization letter from the manufacturer to be uploaded.
- 3.Details of EMD submitted-bank transfer details.
- 4.Detailed Technical specification of the Catalyst offered as per Annexure III.
5. Proof of satisfactorily meeting all the Eligibility criteria Conditions given in Annexure-VII.
- 6.Signed copy of the terms and conditions of the enquiry as given in Annexure-VIII.

PRICE BID FORMAT

BIDDERS MAY PLEASE MENTION WHETHER "QUOTED" OR "NOT QUOTED" IN EACH COLUMN OF THE UN PRICED BOQ FORMAT AND UPLOAD THE SAME ALONG WITH OTHER TENDER DOCUMENTS.

वाणिज्यिकअवधिप्रपत्रCOMMERCIAL TERM FORMAT

(आपकेपत्रशीर्षएवंमुद्रितकरअपलोडकियाजाए)
(To be printed on your letter head& uploaded)

(कृपयाअपनेपत्रशीर्षमेंनीचेदियेगएविवरणभरेंऔरअपनीबोलीकेसाथअपलोडकियाजाए)
(Please fill up the details mentioned below in your letter head and upload along with your bid)

संगठनकानामऔरपता

Name and Address of Organization:

फोननंबर / मोबाइलनंबर.

Phone No/ Mobile No.

जीएसटीआईएनGSTIN :

संपर्कअधिकारीकेनामऔरदूरभाषसं

Contact Person Name and Mobile No:

पत्राचारकेलिएईमेलआईडी

E-mail id for correspondence:

एमएसएमई/एनएसआईसीकेसाथपंजीकृतहै

Whether registered with MSME/NSIC:

(यदिहाँतोदस्तावेजप्रमाणसंलग्नकरें)

(If so pl. enclose documentary proof)

प्रस्तावितउत्पादकानाम:

Name of offered product:

मात्रा:

Quantity:

दीगयीभुगतानअवधिPayment Term:

दिये गए वितरण शर्तें Terms of delivery:

प्रस्तावकी वैधता Validity of offer:

वितरण अवधि Delivery period:

लागू कर Taxes Applicable:

आपूर्तिके साथ प्रदान प्रमाणपत्र Certificates provided along with supply.

विनिर्देशनमें विचलन यदि कोई हो तो Deviation to tender terms if any:

हस्ताक्षर और मोहर Signature and Stamp

ANNEXURE XI - B

(KINDLY FILL THIS SHEET AND SUBMIT IN -COMMERCIAL/TECHNICAL BID)

| Name of Bidder: | | |
|-------------------------------|--|--|
| Sr. No. | Commercial Clauses | Bidder Confirmation (Please put v in front of your confirmation) |
| 1 | Whether bidder (a proprietary concern, Partnership Firm, Company) is currently on holiday list/black list/de-listed or has been put on holiday/blacklisted/de-listed at any PSU/govt. Organization. If so, give details. | <input type="checkbox"/> Yes, We are on holiday List/Black List/De-List <input type="checkbox"/> No |
| 2i | Whether the party is registered under Micro/Small/Medium Enterprises act 2006 (Please furnish the proof) | <input type="checkbox"/> Micro <input type="checkbox"/> Medium <input type="checkbox"/> Small <input type="checkbox"/> No |
| 2-ii | Status of MSE Bidder | <input type="checkbox"/> Manufacturer <input type="checkbox"/> Services <input type="checkbox"/> Not Applicable |
| 2-iii | Whether MSE bidder is offering product manufactured by him/her | <input type="checkbox"/> Yes <input type="checkbox"/> No |
| 3i | All MSE bidders shall register / declare their UAM Number on CPP Portal and copy of this registration / declaration shall be attached with the offer; failing which such bidders will not be able to enjoy benefits as per PP Policy for MSME order, 2012. <u>SSI/MSME/NSIC/UAM /DIC registration certificate</u> | <input type="checkbox"/> Mention UAM Number <input type="checkbox"/> Not Applicable |
| 3-ii | Submitted valid document against clause no 3i | <input type="checkbox"/> Submitted <input type="checkbox"/> Not Applicable |
| 4i | Whether the proprietor of "MSME" enterprise is from SC/ST category. (Please attach caste certificate issued by competent authority) | <input type="checkbox"/> Yes <input type="checkbox"/> No |
| 4ii | Whether the proprietor of "MSME" enterprise is woman (i.e. Woman proprietorship, or holding minimum 51% shares in case of Partnership/Private Limited Companies) | <input type="checkbox"/> Yes <input type="checkbox"/> No |
| 4iii | Submitted certificate against clause no 4ii | <input type="checkbox"/> Submitted <input type="checkbox"/> Not Applicable |
| 5 | AGREED TO ALL TERMS AND CONDITIONS OF ENQUIRY: It is hereby stated that the quotation/offer submitted is in full compliance with the documents issued against the enquiry and also further confirmed that there is no deviation from all the terms and conditions as per the enquiry. Non-acceptance or deviation to HOCL's standard terms and conditions mentioned in enquiry documents may lead to rejection of offer, no correspondence shall be done for clarifications | <input type="checkbox"/> Agreed <input type="checkbox"/> Not Agreed |
| DATE:SIGN AND STAMP OF BIDDER | | |

| <u>ANNEXURE XI - C</u> | | |
|---|---|--|
| (For Purchase Order/ Work Order with estimated value more than FIVE Lakhs) ANNEXURE TO BE SUBMITTED ALONG WITH THE BID AGAINST TENDER NO _____ (KINDLY FILL AND SUBMIT ALONG WITH COMMERCIAL/TECHNICAL BID) | | |
| NAME OF BIDDER: | | |
| Sl.No. | COMMERCIAL CLAUSES | BIDDER CONFIRMATION (PLEASE PUT √) |
| 1 | Please mention whether you are a Class-I/Class II Local supplier.(Please see the definition given below) | Class I |
| | | Class II |
| 2 | Specify the percentage (%) of local content. | _____ % |
| 3 | Details of location at which the local value addition is made. | |
| 4 | Mention whether the product offered is manufactured in India under a license from a foreign manufacturer who hold intellectual property rights and there is a technology collaboration agreement / Transfer of technology agreement | Yes / No |
| <u>SELF DECLARATION OF LOCAL CONTENT</u> | | |
| <p>We hereby declare that the percentage(%) of local content specified against mentioned against Sr.No.2 is _____%. We also understand that submitting False self-declarations and auditors will be in breach of Code of Integrity under Rule 175(1)(i)(h) of the General Financial Rules for which a Bidder or its successors can be debarred for up to Two Years as per the Rule 151 (iii) of the General. Financial Rules along with such other actions as may be permissible under Law.</p> <p>Definitions</p> <p>Local Content: - The amount of value added in India(Total value of item procured minus the value of imported content in the item(including all customs duties) as a proportion of total value, in percentage.</p> <p>Class I Local Supplier: - Supplier or service provider whose goods, services or works offered for procurement has local content equal to or more than 50%.</p> <p>Class II Local Supplier: - Supplier or service provider whose goods, services or works offered for procurement has local content more than 20% but less than 50 %.</p> <p>Purchase Preference: -Will be as per the applicable Government order.</p> | | |
| DATE | | SIGNATURE AND STAMP |

INTEGRITY PACT FORMAT

INTEGRITY PACT

Between

Hindustan Organic Chemicals Ltd(HOCL), a company formed and registered under the Companies Act,1956 and having its registered office at 4th Floor, V Times square, Sector-15, CBD Belapur, Navi Mumbai-400 614, Maharashtra hereinafter referred to as "The Principal",

And

..... herein after referred to as "The Bidder/Contractor"

Preamble

The Principal intends to award, under laid down organizational procedures, contract/s for The Principal values full compliance with all relevant laws of the land, rules, regulations, economic use of resources and of fairness / transparency in its relations with its Bidder(s) and / or Contractor(s).

In order to achieve these goals, the Principal will appoint an Independent External Monitor (IEM), who will monitor the tender process and the execution of the contract for compliance with the principles mentioned above.

Section 1- Commitments of the Principal

1. The Principal commits itself to take all measures necessary to prevent corruption and to observe the following principles:-
 - a) No employee of the Principal, personally or through family members will in connection with the tender for, or the execution of a contract, demand, take a promise for or accept, for self or third person, any material or immaterial benefit which the person is not legally entitled to.
 - b) The Principal will, during the tender process treat all bidders(s) with equity and reason. The Principal will in particular, before and during the tender process, provide to all Bidder(s) the same information and will not provide to any Bidder(s) confidential/additional information through which the Bidder(s) could obtain an advantage in relation to the tender process or the contract execution.
 - c) The Principal will exclude from the process all known prejudiced / interested persons.

2. If the Principal obtains information on the conduct of any of its employees which is a criminal offence under the Indian Penal code/Prevention of Corruption Act, or if there be a substantive suspicion in this regard, the Principal will inform the Chief Vigilance Officer and in addition can initiate disciplinary actions.

Section 2 - Commitments of the Bidder(s)/ Contractor(s)

1. The Bidder(s)/ Contractor(s) commit themselves to take all measures necessary to prevent corruption. He commits himself to observe the following principles during his participation in the tender process and during the contract execution.
 - a) The Bidder(s) / Contractor(s) will not, directly or through any other person or firm, offer, promise or give to any of the Principal's employees involved in the tender process or the execution of the contract or to any third person any material or other benefit which he/she is not legally entitled to, in order to obtain in exchange any advantage of any kind whatsoever during the tender process or during the execution of the contract.
 - b) A Bidder(s)/Contractor(s) will not enter with other Bidders into any undisclosed agreement or understanding, whether formal or informal. This applies in particular to prices, specifications, certifications, subsidiary contracts, submission or non submission of bids or any other actions to restrict competitiveness or to introduce cartelisation in the bidding process.
 - c) The Bidder(s) / Contractor(s) will not commit any offence under the relevant IPC/PC Act; further the Bidder(s) / Contractor(s) will not use improperly, for purposes of competition or personal gain, or pass on to others, any information or document provided by the Principal as part of the business relationship, regarding plans, technical proposals and business details, including information contained or transmitted electronically.
 - d) The Bidder(s) /contractor(s) of foreign origin shall disclose the name and address of the Agents/representatives in India, if any. Similarly, the bidder(s)/contractor(s) of Indian Nationality shall furnish the name and address of the foreign principals, if any. All the payments made to the India agent/representative have to be in Indian Rupees only.
 - e) The Bidder(s)/Contractor(s) will, when presenting his bid, disclose any and all payments he has made, is committed to or intends to make to agents, brokers or any other intermediaries in connection with the award of the contract.
2. The Bidder(s) / Contractor(s) will not instigate third persons to commit offences outlined above or be an accessory to such offences.

Section 3- Disqualification from tender process and exclusion from future contracts

If the Bidder(s) / Contractor(s), before award or during execution has committed a transgression through a violation of Section 2 above or in any other from such as to put his reliability or credibility in question, the Principal is entitled to disqualify the Bidders/ Contractor(s) from the tender process or to terminate the contract, if already signed, for such reasons.

Section 4- Compensation for Damages

1. If the Principal has disqualified the Bidder(s) from the tender process prior to the award according to Section 3, the Principal is entitled to demand and recover the damages equivalent to Earnest Money Deposit/Bid Security.
2. If the Principal has terminated the contract according to Section 3, or if the Principal is entitled to terminate the contract according to Section 3, the Principal shall be entitled to demand and recover from the Contractor the liquidated damages of the Contract value or the amount equivalent to Performance Bank Guarantee.

Section 5- Previous transgression

1. The Bidder declares that no previous transgressions occurred in the last 3 years with any other company in India conforming to the anti- corruption approach including Public Sector Enterprise in India that could justify his exclusion from the tender process.
2. If the bidder makes incorrect statement on this subject, he can be disqualified from the tender process and appropriate action can be taken including termination of the contract, if already awarded, for such reason.

Section-6- Equal treatment of all Bidders / Contractors / Subcontractors

1. The Bidder(s) / Contractor(s) undertake(s) to demand from all subcontractors a commitment in conformity with this Integrity Pact, and to submit it to the Principal before contract signing.
2. The Principal will enter into agreements with identical conditions as this one with all Bidders, Contractors and Subcontractor.
3. The Principal will disqualify from the tender process all bidders who do not sign this Pact or violate its provisions.

Section-7- Criminal charges against violating Bidder(s)/ Contractor(s) /Subcontractor (s)

If the Principal obtains knowledge of conduct of a Bidder, Contractor or Subcontractor, or of an employee or a representative or an associate of a Bidder, Contractor or Subcontractor which constitutes corruption, or if the Principal has substantive suspicion in this regard, the Principal will inform the same to the Chief Vigilance Officer.

Section 8 - Independent External Monitor / Monitors

1. The Principal appoints competent and credible Independent External Monitor for this Pact. The task of the Monitor is to review independently and objectively, whether and to what extent the parties comply with the obligations under this agreement.
2. The Monitor is not subject to instructions by the representatives of the parties and performs his functions neutrally and independently. It will be obligatory for him to treat the information and documents of the Bidder(s) / Contractor(s) as confidential. He reports to the Chairman and Managing Director, HOCL.

3. The Bidder(s) / Contractor(s) accepts that the Monitor has the right to access without restriction to all Project documentation of the Principal including that provided by the Contractor. The contractor will also grant the Monitor, upon his request and demonstration of a valid interest, unrestricted and unconditional access to his project documentation. The same is applicable to Sub contractors. The Monitor is under contractual obligation to treat the information and documents of the Bidder(s) / Contractor(s) / Subcontractors(s) with confidentiality.
4. The Principal will provide to the Monitor sufficient information about all meetings among the parties related to the Project provided such meetings could have an impact on the contractual relations between the Principal and the Contractor. The parties offer to the Monitor the option to participate in such meeting.
5. As soon as the Monitor notices, or believes to notice, a violation of this agreement he will so inform the management of the Principal and request the Management to discontinue or take corrective action, or to take other relevant action. The Monitor can in this regard submit non-binding recommendations. Beyond this, the Monitor has no right to demand from the parties that they act in a specific manner, refrain from action or tolerate action.
6. The Monitor will submit a written report to the Chairman and Managing Director, HOCL within 8 to 10 weeks from the date of reference or intimation to him by the Principal and should the occasion arise, submit proposals for correcting problematic situations.
7. Monitor shall be entitled to compensation on the same terms as being extended to / provided to Independent Directors on HOCL Board.
8. If the Monitor has reported to the Chairman & Managing Director, HOCL, a substantiated suspicion of an offence under relevant IPC/PC Act, and the Chairman & Managing Director, HOCL has not, within the reasonable time taken visible action to proceed against such offence or reported it to the Chief Vigilance Officer, the Monitor may also transmit this information directly to the Central Vigilance Commissioner.
9. The word '**Monitor**' would include both singular and plural.

10. Independent External Monitor Details:

- i. Name: Rajnisha Kumar Vaish, IAS (Retd.)

Mob No.: 9013807422

Address: Plot No.10, Greenwoods Govt. Officers Welfare Society Phase II,

Sector Omega 1, Pocket P2, Greater Noida,

Dist. GautamBudh Nagar, U.P.-201310

Email ID: rajnishakumar@gmail.com

- ii. Name: Arun Kumar Gupta

Mob No.:9833880764

Address: E-68B, Nandanvan CHS.

Sector 17, Nerul,

Navi Mumbai, Maharashtra, Pin-400706

E-mail ID: guptaarung55@rediffmail.com**Section 9 - Pact Duration**

This Pact begins when both parties have legally signed it. It expires for the Contractor 12 months after the last payment under the contract, and for all other bidder(s) 6 months after the contract has been awarded.

If any claim is made/lodged during this time, the same shall be binding and continue to be valid despite the lapse of this Pact as specified above, unless it is discharged/determined by the Chairman and Managing Director of HOCL.

Section 10 - Other provisions

1. This agreement is subject to Indian Law. Place of performance and jurisdiction is the Registered Office of the Principal, i.e. Navi Mumbai, Maharashtra.
2. Changes and supplements as well as termination notices need to be made in writing. Side agreements have not been made.
3. If the Contractor is a partnership or a consortium, this agreement must be signed by all partners or consortium members.
4. Should one or several provisions of the agreement turn out to be invalid, the remainder of this agreement remains valid. In this case, the parties will strive to come to an agreement to their original intentions.
5. The Bidder / Contractor signing this "Integrity Pact" shall not approach the courts while representing the matters to IEMs and he/she shall wait their decisions in the matter.

| | |
|--|---|
| For & On behalf of the Principal (Office Seal) | For & On behalf of Bidder/Contractor(Office Seal) |
| Place: | |
| Date: | |
| Witness 1 (Name & Address) | Witness 2: (Name & Address) |

BID SECURITY DECLARATION

ANNEXURE TO BE SUBMITTED ALONG WITH THE BID AGAINST TENDER NO _____

I/We.....hereby declare that:

- 1.** I will not revoke the tender within the stipulated period/ validity period OR increase the quoted rates.
- 2.** I will commence the work on receipt of Purchase Order.
- 3.** I will not withdraw or amend the tender or impair or derogate from the tender in any respect within the period of validity of the tender.
- 4.** I will furnish the required performance security within the specified period.

NAME AND ADDRESS OF THE BIDDER

PLACE:

DATE:

SIGNATURE AND STAMP OF THE BIDDER

ANNEXURE-XIV

COMPLIANCE TO CLAUSE W.R.T MANADATORY REGISTRATION OF VENDORS FROM COUNTRIES SHARING LAND BORDER WITH INDIA, WITH DPIIT

Date:

TO WHOMSOEVER IT MAY CONCERNS

"I have read The clause titled restrictions on procurement from a bidder of a country which shares a land border with India.

I certify that M/s.....(Name Bidder) is not from such a country

Or .

I hereby certify that M/s.(name of Bidder) is from a country which shares land border with India and fulfills all requirements in this regard and is eligible to be considered. Enclosed herewith Valid Registration Certificate

Or

I hereby certify that M/s..... (Name of Bidder) is from such a country which shares land border with India , however the said requirement of registration will not be applicable to bidders as Govt. of India has extended lines of credit or in which Govt. of India is engaged in development of projects. Enclosed herewith documentary evidence in this regards

We confirm that if it is established that we have provided any false information in pursuance to above clause, while competing for this contract then our Bid shall be rejected.

We further confirms that, if it is established that we have not complied with terms of aforesaid clause, during execution of contract, this would be a sufficient ground for immediate termination of the contract as per tender provision and shall be dealt accordingly.

Name of the Bidder

Stamp & Signature of the Bidder

Bid Document

| Bid Details | |
|--|---|
| Bid End Date/Time | 27-09-2022 14:00:00 |
| Bid Opening Date/Time | 27-09-2022 14:30:00 |
| Bid Offer Validity (From End Date) | 120 (Days) |
| Ministry/State Name | Ministry Of Chemicals And Fertilizers |
| Department Name | Department Of Chemicals And Petrochemicals |
| Organisation Name | Hindustan Organic Chemicals Limited |
| Office Name | Ambalamugal,ernakulam |
| Total Quantity | 84 |
| Item Category | SPA CATALYST |
| BOQ Title | SOLID PHOSPHORIC ACID CATALYST |
| Years of Past Experience Required for same/similar service | 3 Year (s) |
| MSE Exemption for Years Of Experience | Yes |
| Startup Exemption for Years Of Experience | Yes |
| Document required from seller | Experience Criteria,Past Performance,Certificate (Requested in ATC),OEM Authorization Certificate,Compliance of BoQ specification and supporting document *In case any bidder is seeking exemption from Experience / Turnover Criteria, the supporting documents to prove his eligibility for exemption must be uploaded for evaluation by the buyer |
| Past Performance | 80 % |
| Bid to RA enabled | No |
| Time allowed for Technical Clarifications during technical evaluation | 2 Days |
| Evaluation Method | Total value wise evaluation |

EMD Detail

| | |
|----------|----|
| Required | No |
|----------|----|

ePBG Detail

| | |
|----------|----|
| Required | No |
|----------|----|

Splitting

Bid splitting not applied.

MII Purchase Preference

| | |
|-------------------------|-----|
| MII Purchase Preference | Yes |
|-------------------------|-----|

MSE Purchase Preference

| | |
|-------------------------|-----|
| MSE Purchase Preference | Yes |
|-------------------------|-----|

1. If the bidder is a Micro or Small Enterprise as per latest definitions under MSME rules, the bidder shall be exempted from the requirement of "Bidder Turnover" criteria and "Experience Criteria" subject to meeting of quality and technical specifications. If the bidder is OEM of the offered products, it would be exempted from the "OEM Average Turnover" criteria also subject to meeting of quality and technical specifications. In case any bidder is seeking exemption from Turnover / Experience Criteria, the supporting documents to prove his eligibility for exemption must be uploaded for evaluation by the buyer.
2. If the bidder is a Startup, the bidder shall be exempted from the requirement of "Bidder Turnover" criteria and "Experience Criteria" subject to their meeting of quality and technical specifications. If the bidder is OEM of the offered products, it would be exempted from the "OEM Average Turnover" criteria also subject to meeting of quality and technical specifications. In case any bidder is seeking exemption from Turnover / Experience Criteria, the supporting documents to prove his eligibility for exemption must be uploaded for evaluation by the buyer.
3. Experience Criteria: In respect of the filter applied for experience criteria, the Bidder or its OEM {themselves or through reseller(s)} should have regularly, manufactured and supplied same or similar Category Products to any Central / State Govt Organization / PSU / Public Listed Company for number of Financial years as indicated above in the bid document before the bid opening date. Copies of relevant contracts to be submitted along with bid in support of having supplied some quantity during each of the Financial year. In case of bunch bids, the category of primary product having highest value should meet this criterion.
4. Preference to Make In India products (For bids < 200 Crore): Preference shall be given to Class 1 local supplier as defined in public procurement (Preference to Make in India), Order 2017 as amended from time to time and its subsequent Orders/Notifications issued by concerned Nodal Ministry for specific Goods/Products. The minimum local content to qualify as a Class 1 local supplier is denoted in the bid document. If the bidder wants to avail the Purchase preference, the bidder must upload a certificate from the OEM regarding the percentage of the local content and the details of locations at which the local value addition is made along with their bid, failing which no purchase preference shall be granted. In case the bid value is more than Rs 10 Crore, the declaration relating to percentage of local content shall be certified by the statutory auditor or cost auditor, if the OEM is a company and by a practicing cost accountant or a chartered accountant for OEMs other than companies as per the Public Procurement (preference to Make-in -India) order 2017 dated 04.06.2020. Only Class-I and Class-II Local suppliers as per MII order dated 4.6.2020 will be eligible to bid. Non - Local suppliers as per MII order dated 04.06.2020 are not eligible to participate. However, eligible micro and small enterprises will be allowed to participate .In case Buyer has selected Purchase preference to Micro and Small Enterprises clause in the bid, the same will get precedence over this clause.
5. Purchase preference to Micro and Small Enterprises (MSEs): Purchase preference will be given to MSEs as defined in Public Procurement Policy for Micro and Small Enterprises (MSEs) Order, 2012 dated 23.03.2012 issued by Ministry of Micro, Small and Medium Enterprises and its subsequent Orders/Notifications issued by concerned Ministry. If the bidder wants to avail the Purchase preference, the bidder must be the manufacturer of the offered product in case of bid for supply of goods. Traders are excluded from the purview of Public Procurement Policy for Micro and Small Enterprises. In respect of bid for Services, the bidder must be the Service provider of the offered Service. Relevant documentary evidence in this regard shall be uploaded along with the bid in respect of the offered product or service. If L-1 is not an MSE and MSE Seller (s) has/have quoted price within L-1+ 15% (Selected by Buyer)of margin of purchase preference /price band defined in relevant policy, such Seller shall be given opportunity to match L-1 price and contract will be awarded for 25%(selected by Buyer) percentage of total QUANTITY.
6. Estimated Bid Value indicated above is being declared solely for the purpose of guidance on EMD amount and for determining the Eligibility Criteria related to Turn Over, Past Performance and Project / Past Experience etc. This has no relevance or bearing on the price to be quoted by the bidders and is also not going to have any impact on bid participation. Also this is not going to be used as a criteria in determining reasonableness of quoted prices which would be determined by the buyer based on its own assessment of reasonableness and

based on competitive prices received in Bid / RA process.

7. Past Performance: The Bidder or its OEM {themselves or through re-seller(s)} should have supplied same or similar Category Products for 80% of bid quantity, in at least one of the last three Financial years before the bid opening date to any Central / State Govt Organization / PSU / Public Listed Company. Copies of relevant contracts (proving supply of cumulative order quantity in any one financial year) to be submitted along with bid in support of quantity supplied in the relevant Financial year. In case of bunch bids, the category related to primary product having highest bid value should meet this criterion.

SPA CATALYST

(Minimum 50% and 20% Local Content required for qualifying as Class 1 and Class 2 Local Supplier respectively)

| | |
|------------|-----------|
| Brand Type | Unbranded |
|------------|-----------|

Technical Specifications

| | |
|-------------------------------|---------------------------|
| Specification Document | View File |
| BOQ Detail Document | View File |

Advisory-Please refer attached BOQ document for detailed consignee list and delivery period.

Consignees/Reporting Officer and Quantity

| S.No. | Consignee/Reporting Officer | Address | Quantity | Delivery Days |
|-------|-----------------------------|--|----------|---------------|
| 1 | Balachandran B | 682302,HINDUSTAN ORGANIC CHEMICALS LTD, AMBALAMUGAL ERNAKULAM | 84 | 180 |

Buyer Added Bid Specific Terms and Conditions

1. Generic

OPTION CLAUSE: The Purchaser reserves the right to increase or decrease the quantity to be ordered up to 25 percent of bid quantity at the time of placement of contract. The purchaser also reserves the right to increase the ordered quantity by up to 25% of the contracted quantity during the currency of the contract at the contracted rates. Bidders are bound to accept the orders accordingly.

2. Generic

Bidders are advised to check applicable GST on their own before quoting. Buyer will not take any responsibility in this regards. GST reimbursement will be as per actuals or as per applicable rates (whichever is lower), subject to the maximum of quoted GST %.

3. **Generic**

Buyer Organization specific Integrity Pact shall have to be complied by all bidders. Bidders shall have to upload scanned copy of signed integrity pact as per Buyer organizations policy along with bid. [Click here to view the file](#)

4. **Generic**

Bidder shall submit the following documents along with their bid for Vendor Code Creation:

- a. Copy of PAN Card.
- b. Copy of GSTIN.
- c. Copy of Cancelled Cheque.
- d. Copy of EFT Mandate duly certified by Bank.

5. **Generic**

Data Sheet of the product(s) offered in the bid, are to be uploaded along with the bid documents. Buyers can match and verify the Data Sheet with the product specifications offered. In case of any unexplained mismatch of technical parameters, the bid is liable for rejection.

6. **Generic**

Experience Criteria: The Bidder or its OEM {themselves or through reseller(s)} should have regularly, manufactured and supplied same or similar Category Products to any Central / State Govt Organization / PSU / Public Listed Company for 3 years before the bid opening date. Copies of relevant contracts to be submitted along with bid in support of having supplied some quantity during each of the year. In case of bunch bids, the primary product having highest value should meet this criterion.

7. **Generic**

For hazardous chemical/item, all precautionary measure as per regulation from the point of transportation/ handling/ storage/ safety/ health/ environment to be undertaken/ specified before dispatch. During dispatch, proper symbol for the hazard/ MSDS/ Batch No./ date of manufacturing/ Gross Weight/ Net Weight/ shelf Life etc are to be written/ printed/ pasted on the body of the packing.

8. **Generic**

Products supplied shall be nontoxic and harmless to health. In the case of toxic materials, Material Safety Data Sheet may be furnished along with the material.

9. **Generic**

Upload Manufacturer authorization: Wherever Authorised Distributors are submitting the bid, Manufacturers Authorisation Form (MAF)/Certificate with OEM details such as name, designation, address, e-mail Id and Phone No. required to be furnished along with the bid.

10. **Generic**

Without prejudice to Buyer's right to price adjustment by way of discount or any other right or remedy available to Buyer, Buyer may terminate the Contract or any part thereof by a written notice to the Seller, if:

- i) The Seller fails to comply with any material term of the Contract.
- ii) The Seller informs Buyer of its inability to deliver the Material(s) or any part thereof within the stipulated Delivery Period or such inability otherwise becomes apparent.
- iii) The Seller fails to deliver the Material(s) or any part thereof within the stipulated Delivery Period and/or to replace/rectify any rejected or defective Material(s) promptly.
- iv) The Seller becomes bankrupt or goes into liquidation.
- v) The Seller makes a general assignment for the benefit of creditors.
- vi) A receiver is appointed for any substantial property owned by the Seller.

vii) The Seller has misrepresented to Buyer, acting on which misrepresentation Buyer has placed the Purchase Order on the Seller.

11. **Scope of Supply**

Scope of supply (Bid price to include all cost components) : Only supply of Goods

12. **Purchase Preference (Centre)**

Purchase preference to Micro and Small Enterprises (MSEs): Purchase preference will be given to MSEs as defined in Public Procurement Policy for Micro and Small Enterprises (MSEs) Order, 2012 dated 23.03.2012 issued by Ministry of Micro, Small and Medium Enterprises and its subsequent Orders/Notifications issued by concerned Ministry. If the bidder wants to avail the Purchase preference, the bidder must be the manufacturer of the offered product in case of bid for supply of goods. Traders are excluded from the purview of Public Procurement Policy for Micro and Small Enterprises. In respect of bid for Services, the bidder must be the Service provider of the offered Service. Relevant documentary evidence in this regard shall be uploaded along with the bid in respect of the offered product or service. If L-1 is not an MSE and MSE Seller (s) has/have quoted price within L-1+ 15% of margin of purchase preference /price band defined in relevant policy, such Seller shall be given opportunity to match L-1 price and contract will be awarded for percentage of 25% of total value.

13. **Purchase Preference (Centre)**

Purchase Preference linked with Local Content (PP-LC) Policy:

The bid clause regarding "Preference to Make In India products" stands modified in this bid and shall be governed by the PPLC Policy No. FP-20013/2/2017-FP-PNG dated 17.11.2020 issued by MoP&NG as amended up to date. Accordingly, bidders with Local Content less than or equal to 20% will be treated as "Non Local Supplier". The prescribed LC shall be applicable on the date of Bid opening. Sanctions on the bidders for false / wrong declaration or not fulfilling the Local Content requirement shall be as per the PPLC policy. Further following additional provisions are added in the certification and verification of local content provision of the Preference to Make in India clause:

- i. In case of foreign bidder, certificate from the statutory auditor or cost auditor of their own office or subsidiary in India giving the percentage of local content is also acceptable. In case office or subsidiary in India does not exist or Indian office/subsidiary is not required to appoint statutory auditor or cost auditor, certificate from practicing cost accountant or practicing chartered accountant giving the percentage of local content is also acceptable.
- ii. Along with Each Invoice: The local content certificate (issued by statutory auditor on behalf of procuring company) shall be submitted along with each invoice raised. However, the % of local content may vary with each invoice while maintaining the overall % of local content for the total work/purchase of the pro-rata local content requirement. In case, it is not satisfied cumulatively in the invoices raised up to that stage, the supplier shall indicate how the local content requirement would be met in the subsequent stages.
- iii. The bidder shall submit an undertaking from the authorized signatory of bidder having the Power of Attorney along with the bid stating the bidder meets the mandatory minimum LC requirement and such undertaking shall become a part of the contract.

14. **Certificates**

Bidder's offer is liable to be rejected if they don't upload any of the certificates / documents sought in the Bid document, ATC and Corrigendum if any.

15. **Certificates**

Material Test Certificate Should Be Sent Along with The Supply. The Material Will Be Checked by Buyer's Lab & the Results of the Lab will be the Sole Criteria for Acceptance of the Item.

16. **Certificates**

The bidder is required to upload, along with the bid, all relevant certificates such as BIS licence, type test certificate, approval certificates and other certificates as prescribed in the Product Specification given in the bid document.

17. Certificates

To be eligible for award of contract, Bidder / OEM must possess following Certificates / Test Reports on the date of bid opening (to be uploaded with bid): 1. Detailed Technical specification of the Catalyst offered .2. Manufacturers test certificate of the item & Guarantee certificate for the specific yield for the product. 3.Proof of satisfactorily meeting all the Eligibility criteria Conditions ..

18. Past Project Experience

For fulfilling the experience criteria any one of the following documents may be considered as valid proof for meeting the experience criteria:

- a. Purchase Order copy along with Invoice(s) with self-certification by the bidder that supplies against the invoices have been executed.
- b. Execution certificate by client with order value.
- c. Any other document in support of order execution like Third Party Inspection release note, etc.

19. Past Project Experience

The Bidder / OEM {themselves or through reseller(s)}, should have executed project for supply and installation / commissioning of same or similar Category Products during preceding 3 financial years (i.e. current year and three previous financial years) as on opening of bid, as per following criteria:

- (i) Single order of at least 35% of estimated bid value; or
 - (ii) Two orders of at least 20% each of estimated bid value; or
 - (iii) Three orders of at least 15% each of estimated bid value.
- Satisfactory Performance certificate issued by respective Buyer Organization for the above Orders should be uploaded with bid. In case of bunch bids, the Category related to primary product having highest bid value should meet this criterion

20. Buyer Added Bid Specific ATC

Buyer Added text based ATC clauses

Kindly submit the following documents:

- 1.Your covering letter of the offer on your company letter head.

- 2.If you are the authorized distributor of Manufacturer of Catalyst, Authorization letter from the manufacturer to be uploaded.

- 3.Details of EMD submitted-bank transfer details.

- 4.Detailed Technical specification of the Catalyst offered.

- 5. Proof of satisfactorily meeting all the Eligibility criteria Conditions.
- 6.Signed copy of the terms and conditions of the enquiry.

21. Buyer Added Bid Specific ATC

Buyer uploaded ATC document [Click here to view the file.](#)

22. Generic

Bidder financial standing: The bidder should not be under liquidation, court receivership or similar proceedings, should not be bankrupt. Bidder to upload undertaking to this effect with bid.

Disclaimer

The additional terms and conditions have been incorporated by the Buyer after approval of the Competent Authority in Buyer Organization. Buyer organization is solely responsible for the impact of these clauses on the bidding process, its outcome, and consequences thereof including any eccentricity/restriction arising in the bidding process due to these ATCs and due to modification of technical specifications and/or terms and conditions governing the bid. Any clause incorporated by the Buyer such as demanding Tender Sample, incorporating any clause against the MSME policy and Preference to make in India Policy, mandating any Brand names or Foreign Certification, changing the default time period for Acceptance of material or payment timeline governed by OM of Department of Expenditure shall be null and void and would not be considered part of bid. Further any reference of conditions published on any external site or reference to external documents/clauses shall also be null and void. If any seller has any objection/grievance against these additional clauses or otherwise on any aspect of this bid, they can raise their representation against the same by using the Representation window provided in the bid details field in Seller dashboard after logging in as a seller within 4 days of bid publication on GeM. Buyer is duty bound to reply to all such representations and would not be allowed to open bids if he fails to reply to such representations. Also, GeM does not permit collection of Tender fee / Auction fee in case of Bids / Forward Auction as the case may be. Any stipulation by the Buyer seeking payment of Tender Fee / Auction fee through ATC clauses would be treated as null and void.

[This Bid is also governed by the General Terms and Conditions](#)

In terms of GeM GTC clause 26 regarding Restrictions on procurement from a bidder of a country which shares a land border with India, any bidder from a country which shares a land border with India will be eligible to bid in this tender only if the bidder is registered with the Competent Authority. While participating in bid, Bidder has to undertake compliance of this and any false declaration and non-compliance of this would be a ground for immediate termination of the contract and further legal action in accordance with the laws.

---Thank You---