

बिड दस्तावेज़ / Bid Document

बिड विवरण/Bid Details	
बिड बंद होने की तारीख/समय /Bid End Date/Time	03-06-2026 14:00:00
बिड खुलने की तारीख/समय /Bid Opening Date/Time	03-06-2026 14:30:00
बिड पेशकश वैधता (बंद होने की तारीख से)/Bid Offer Validity (From End Date)	60 (Days)
मंत्रालय/राज्य का नाम/Ministry/State Name	Ministry Of Chemicals And Fertilizers
विभाग का नाम/Department Name	Department Of Chemicals And Petrochemicals
संगठन का नाम/Organisation Name	Hindustan Organic Chemicals Limited
कार्यालय का नाम/Office Name	Ambalamugal,ernakulam
कुल मात्रा/Total Quantity	156
वस्तु श्रेणी /Item Category	WALL TUBE HANGER , ARCH SECTION TUBE HANGER , TUBE HANGER , HINGE PIN , SUPPORTING PLATE
GeMARPTS में खोजी गई स्ट्रिंग्स / Searched Strings used in GeMARPTS	HOT OIL FURNACE TUBE SUPPORTING HANGERS
GeMARPTS में खोजा गया परिणाम / Searched Result generated in GeMARPTS	Category not available on GeM for the text string uploaded by the buyer
अधिसूचना के लिए चयनित प्रासंगिक श्रेणियाँ / Relevant Categories selected for notification	<ul style="list-style-type: none"> Tubular Furnace
बीओक्यू शीर्षक /BOQ Title	HOT OIL FURNACE TUBE SUPPORTING HANGERS
उन्हीं/समान सेवा के लिए अपेक्षित विगत अनुभव के वर्ष/Years of Past Experience Required for same/similar service	3 Year (s)
वर्षों के अनुभव के लिए एमएसई को छूट प्राप्त है / MSE Relaxation for Years Of Experience	Yes Complete
वर्षों के अनुभव के लिए स्टार्टअप को छूट प्राप्त है / Startup Relaxation for Years Of Experience	Yes Complete
विक्रेता से मांगे गए दस्तावेज़/Document required from seller	Experience Criteria,Past Performance,Certificate (Requested in ATC),OEM Authorization Certificate,Additional Doc 1 (Requested in ATC),Compliance of BoQ specification and supporting document *In case any bidder is seeking exemption from Experience / Turnover Criteria, the supporting documents to prove his eligibility for exemption must be uploaded for evaluation by the buyer

बिड विवरण/Bid Details	
क्या आप निविदाकारों द्वारा अपलोड किए गए दस्तावेजों को निविदा में भाग लेने वाले सभी निविदाकारों को दिखाना चाहते हैं? संदर्भ मेनू है/Do you want to show documents uploaded by bidders to all bidders participated in bid?	Yes (Documents submitted as part of a clarification or representation during the tender/bid process will also be displayed to other participated bidders after log in)
बिड लगाने की समय सीमा स्वतः नहीं बढ़ाने के लिए आवश्यक बिड की संख्या। / Minimum number of bids required to disable automatic bid extension	3
दिनों की संख्या, जिनके लिए बिड लगाने की समय-सीमा बढ़ाई जाएगी। / Number of days for which Bid would be auto-extended	7
ऑटो एक्सटेंशन अधिकतम कितनी बार किया जाना है। / Number of Auto Extension count	1
विगत प्रदर्शन /Past Performance	80 %
बिड से रिवर्स नीलामी सक्रिय किया/Bid to RA enabled	No
बिड का प्रकार/Type of Bid	Two Packet Bid
प्राथमिक उत्पाद श्रेणी/Primary product category	WALL TUBE HANGER
तकनीकी मूल्यांकन के दौरान तकनीकी स्पष्टीकरण हेतु अनुमत समय /Time allowed for Technical Clarifications during technical evaluation	2 Days
निरीक्षण आवश्यक (सूचीबद्ध निरीक्षण प्राधिकरण /जेम के साथ पूर्व पंजीकृत एजेंसियों द्वारा)/Inspection Required (By Empanelled Inspection Authority / Agencies pre-registered with GeM)	No
Payment Timelines	Payments shall be made to the Seller within 30 days of issue of consignee receipt-cum-acceptance certificate (CRAC) and on-line submission of bills (This is in supersession of 10 days time as provided in clause 12 of GeM GTC)
मूल्यांकन पद्धति/Evaluation Method	Total value wise evaluation
मध्यस्थता खंड/Arbitration Clause	No
सुलह खंड/Mediation Clause	No

ईएमडी विवरण/EMD Detail

एडवाइजरी बैंक/Advisory Bank	State Bank of India
ईएमडी राशि/EMD Amount	13950

ईपीबीजी विवरण /ePBG Detail

आवश्यकता/Required

No

(a). जेम की शर्तों के अनुसार ईएमडी छूट के इच्छुक बिडर को संबंधित केटेगरी के लिए बिड के साथ वैध समर्थित दस्तावेज़ प्रस्तुत करने हैं। एमएसई केटेगरी के अंतर्गत केवल वस्तुओं के लिए विनिर्माता तथा सेवाओं के लिए सेवा प्रदाता ईएमडी से छूट के पात्र हैं। व्यापारियों को इस नीति के दायरे से बाहर रखा गया है।/EMD EXEMPTION: The bidder seeking EMD exemption, must submit the valid supporting document for the relevant category as per GeM GTC with the bid. Under MSE category, only manufacturers for goods and Service Providers for Services are eligible for exemption from EMD. Traders are excluded from the purview of this Policy.

(b).ईएमडी और संपादन जमानत राशि, जहां यह लागू होती है, लाभार्थी के पक्ष में होनी चाहिए। / EMD & Performance security should be in favour of Beneficiary, wherever it is applicable.

लाभार्थी /Beneficiary :

CGM MATERIALS

Ambalamugal,ernakulam, Department of Chemicals and Petrochemicals, Hindustan Organic Chemicals Limited, Ministry of Chemicals and Fertilizers (Hindustan Organic Chemicals Ltd)

बोली विभाजन लागू नहीं किया गया/ Bid splitting not applied.

एमआईआई खरीद वरीयता / MII Purchase Preference

एमआईआई खरीद वरीयता / MII Purchase Preference	Yes
मेक इन इंडिया विक्रेताओं को खरीद में प्राथमिकता, यदि उनका मूल्य L1+X% तक की सीमा में है / Purchase Preference to MII sellers available upto price within L1+X%	20
मेक इन इंडिया खरीद में प्राथमिकता के लिए बिड की मात्रा का अधिकतम प्रतिशत / Maximum Percentage of Bid quantity for MII purchase preference	50
सार्वजनिक खरीद (मेक-इन-इंडिया को प्राथमिकता) आदेश 2017 के अनुसार केवल क्लास 1/क्लास 2 के स्थानीय आपूर्तिकर्ताओं को ही भागीदारी की अनुमति है दिनांक 16.09.2020 (समय-समय पर संशोधित एवं लागू) / Allow participation only from Class 1/Class 2 local suppliers as per the Public procurement(Preference to Make-in-india) order 2017 date 16.09.2020(as amended and applicable time to time)	Yes, in compliance with the MII ORDER : DPIIT Order(as amended and applicable time to time)

एमएसई खरीद वरीयता/MSE Purchase Preference

एमएसई खरीद वरीयता/MSE Purchase Preference	Yes
सूक्ष्म और लघु उद्यम मूल उपकरण निर्माताओं को खरीद में प्राथमिकता, यदि उनका मूल्य L1+X% तक की सीमा में हो / Purchase Preference to MSE OEMs available upto price within L1+X%	15

सूक्ष्म और लघु उद्यम को खरीद में प्राथमिकता के लिए बिड की मात्रा का अधिकतम प्रतिशत / Maximum Percentage of Bid quantity for MSE purchase preference	25
---	----

ट्रेड्स भुगतान संबंधी विवरण/TReDS Payment Details

This Bid provides for Trade Receivables Discounting System (TReDS) as Preferred mode of payment. For MSME sellers, payments may be processed through a TReDS exchange in which the Buyer is registered, subject to applicable policy and regulatory guidelines. Accordingly, sellers intending to avail payment through TReDS are required to be registered with at least one TReDS exchange in which the buyer is registered.

1. If the bidder is a Micro or Small Enterprise as per latest orders issued by Ministry of MSME, the bidder shall be relaxed from the eligibility criteria of "Experience Criteria" as defined above subject to meeting of quality and technical specifications. The bidder seeking Relaxation from Experience Criteria, shall upload the supporting documents to prove his eligibility for Relaxation.
2. If the bidder is a DPIIT registered Startup, the bidder shall be relaxed from the the eligibility criteria of "Experience Criteria" as defined above subject to their meeting of quality and technical specifications. The bidder seeking Relaxation from Experience Criteria, shall upload the supporting documents to prove his eligibility for Relaxation.
3. Experience Criteria: In respect of the filter applied for experience criteria, the Bidder or its OEM of the product offered in the bid {themselves or through reseller(s)} should have regularly, manufactured and supplied same or similar Category Products to any Central / State Govt Organization / PSU for number of Financial years as indicated above in the bid document before the bid opening date. Copies of relevant contracts and delivery acceptance certificates like CRAC to be submitted along with bid in support of having supplied some quantity during each of the Financial year. In case of bunch bids, the category of primary product having highest value should meet this criterion.
4. Preference to Make In India products (For bids < 200 Crore):Preference shall be given to Class 1 local supplier as defined in public procurement (Preference to Make in India), Order 2017 as amended from time to time and its subsequent Orders/Notifications issued by concerned Nodal Ministry for specific Goods/Products. The minimum local content to qualify as a Class 1 local supplier is denoted in the bid document. If the bidder wants to avail the Purchase preference, the bidder must upload a certificate from the OEM regarding the percentage of the local content and the details of locations at which the local value addition is made along with their bid, failing which no purchase preference shall be granted. In case the bid value is more than Rs 10 Crore, the declaration relating to percentage of local content shall be certified by the statutory auditor or cost auditor, if the OEM is a company and by a practicing cost accountant or a chartered accountant for OEMs other than companies as per the Public Procurement (preference to Make-in -India) order 2017 dated 04.06.2020. Only Class-I and Class-II Local suppliers as per MII order dated 4.6.2020 will be eligible to bid. Non - Local suppliers as per MII order dated 04.06.2020 are not eligible to participate. However, eligible micro and small enterprises will be allowed to participate .The buyers are advised to refer the OM No.F.1/4/2021-PPD dated 18.05.2023. [OM No.1 4 2021 PPD dated 18.05.2023](#) for compliance of Concurrent application of Public Procurement Policy for Micro and Small Enterprises Order, 2012 and Public Procurement (Preference to Make in India) Order, 2017.
5. Purchase preference will be given to MSEs having valid Udyam Registration and whose credentials are validated online through Udyam Registration portal as defined in Public Procurement Policy for Micro and Small Enterprises (MSEs) Order, 2012 dated 23.03.2012 issued by Ministry of Micro, Small and Medium Enterprises and its subsequent Orders/Notifications issued by concerned Ministry. If the bidder wants to avail themselves of the Purchase preference, the bidder must be the manufacturer / OEM of the offered product on GeM. Traders are excluded from the purview of Public Procurement Policy for Micro and Small Enterprises and hence resellers offering products manufactured by some other OEM are not eligible for any purchase preference. In respect of bid for Services, the bidder must be the Service provider of the offered Service. Relevant documentary evidence in this regard shall be uploaded along with the bid in respect of the offered product or service and Buyer will decide eligibility for purchase preference based on documentary evidence submitted, while evaluating the bid. If L-1 is not an MSE and MSE Seller (s) has / have quoted price within L-1+ 15% (Selected by Buyer) of margin of purchase preference /price band defined in relevant policy, such MSE Seller shall be given opportunity to match L-1 price and contract will be awarded for 25% (selected by Buyer) percentage of total quantity. The buyers are advised to refer the OM No. F.1/4/2021-PPD dated 18.05.2023 [OM No.1 4 2021 PPD dated 18.05.2023](#) for compliance of Concurrent application of Public Procurement Policy for Micro and Small Enterprises Order, 2012 and Public Procurement (Preference to Make in India) Order, 2017. Benefits of MSE will be allowed only if seller is

validated on-line in GeM profile as well as validated and approved by Buyer after evaluation of documents submitted.

6. Estimated Bid Value indicated above is being declared solely for the purpose of guidance on EMD amount and for determining the Eligibility Criteria related to Turn Over, Past Performance and Project / Past Experience etc. This has no relevance or bearing on the price to be quoted by the bidders and is also not going to have any impact on bid participation. Also this is not going to be used as a criteria in determining reasonableness of quoted prices which would be determined by the buyer based on its own assessment of reasonableness and based on competitive prices received in Bid / RA process.

7. Past Performance: The Bidder or its OEM {themselves or through re-seller(s)} should have supplied same or similar Category Products for 80% of bid quantity, in at least one of the last three Financial years before the bid opening date to any Central / State Govt Organization / PSU. Copies of relevant contracts (proving supply of cumulative order quantity in any one financial year) to be submitted along with bid in support of quantity supplied in the relevant Financial year. In case of bunch bids, the category related to primary product having highest bid value should meet this criterion.

WALL TUBE HANGER

(क्रमशः श्रेणी 1 और श्रेणी 2 के स्थानीय आपूर्तिकर्ता के रूप में अर्हता प्राप्त करने के लिए आवश्यक/Minimum 50% and 20% Local Content required for qualifying as Class 1 and Class 2 Local Supplier respectively)

तकनीकी विशिष्टियाँ /Technical Specifications

Specification Document	View File
BOQ Detail Document	View File

Advisory-Please refer attached BOQ document for detailed consignee list and delivery period.

परेषिती/रिपोर्टिंग अधिकारी तथा मात्रा/Consignees/Reporting Officer and Quantity

क्र.सं./S.No.	परेषिती/रिपोर्टिंग अधिकारी /Consignee Reporting/Officer	पता/Address	मात्रा /Quantity	डिलीवरी के दिन/Delivery Days
1	Hareesh Madhav A	682302,HOCL AMBALAMUGAL ERNAKULAM	136	60

ARCH SECTION TUBE HANGER

(क्रमशः श्रेणी 1 और श्रेणी 2 के स्थानीय आपूर्तिकर्ता के रूप में अर्हता प्राप्त करने के लिए आवश्यक/Minimum 50% and 20% Local Content required for qualifying as Class 1 and Class 2 Local Supplier respectively)

तकनीकी विशिष्टियाँ /Technical Specifications

Specification Document	View File
BOQ Detail Document	View File

Advisory-Please refer attached BOQ document for detailed consignee list and delivery period.

परेषिती/रिपोर्टिंग अधिकारी तथा मात्रा/Consignees/Reporting Officer and Quantity

क्र.सं./S.N o.	परेषिती/रिपोर्टिंग अधिकारी /Consignee Reporting/Officer	पता/Address	मात्रा /Quantity	डिलीवरी के दिन/Delivery Days
1	Hareesh Madhav A	682302,HOCL AMBALAMUGAL ERNAKULAM	4	60

TUBE HANGER

(क्रमशः श्रेणी 1 और श्रेणी 2 के स्थानीय आपूर्तिकर्ता के रूप में अर्हता प्राप्त करने के लिए आवश्यक/Minimum 50% and 20% Local Content required for qualifying as Class 1 and Class 2 Local Supplier respectively)

तकनीकी विशिष्टियाँ /Technical Specifications

Specification Document	View File
BOQ Detail Document	View File

Advisory-Please refer attached BOQ document for detailed consignee list and delivery period.

परेषिती/रिपोर्टिंग अधिकारी तथा मात्रा/Consignees/Reporting Officer and Quantity

क्र.सं./S.N o.	परेषिती/रिपोर्टिंग अधिकारी /Consignee Reporting/Officer	पता/Address	मात्रा /Quantity	डिलीवरी के दिन/Delivery Days
1	Hareesh Madhav A	682302,HOCL AMBALAMUGAL ERNAKULAM	4	60

HINGE PIN

(क्रमशः श्रेणी 1 और श्रेणी 2 के स्थानीय आपूर्तिकर्ता के रूप में अर्हता प्राप्त करने के लिए आवश्यक/Minimum 50% and 20% Local Content required for qualifying as Class 1 and Class 2 Local Supplier respectively)

तकनीकी विशिष्टियाँ /Technical Specifications

Specification Document	View File
BOQ Detail Document	View File

Advisory-Please refer attached BOQ document for detailed consignee list and delivery period.

परेषिती/रिपोर्टिंग अधिकारी तथा मात्रा/Consignees/Reporting Officer and Quantity

क्र.सं./S.N o.	परेषिती/रिपोर्टिंग अधिकारी /Consignee Reporting/Officer	पता/Address	मात्रा /Quantity	डिलीवरी के दिन/Delivery Days
1	Hareesh Madhav A	682302,HOCL AMBALAMUGAL ERNAKULAM	8	60

SUPPORTING PLATE

(क्रमशः श्रेणी 1 और श्रेणी 2 के स्थानीय आपूर्तिकर्ता के रूप में अर्हता प्राप्त करने के लिए आवश्यक/Minimum 50% and 20% Local Content required for qualifying as Class 1 and Class 2 Local Supplier respectively)

तकनीकी विशिष्टियाँ /Technical Specifications

Specification Document	View File
BOQ Detail Document	View File

Advisory-Please refer attached BOQ document for detailed consignee list and delivery period.

परेषिती/रिपोर्टिंग अधिकारी तथा मात्रा/Consignees/Reporting Officer and Quantity

क्र.सं./S.N o.	परेषिती/रिपोर्टिंग अधिकारी /Consignee Reporting/Officer	पता/Address	मात्रा /Quantity	डिलीवरी के दिन/Delivery Days
1	Hareesh Madhav A	682302,HOCL AMBALAMUGAL ERNAKULAM	4	60

क्रेता द्वारा जोड़ी गई बिड की विशेष शर्तें/Buyer Added Bid Specific Terms and Conditions**1. Generic**

OPTION CLAUSE: The Purchaser reserves the right to increase or decrease the quantity to be ordered up to 25 percent of bid quantity at the time of placement of contract. The purchaser also reserves the right to increase the ordered quantity up to 25% of the contracted quantity during the currency of the contract at the contracted rates. The delivery period of quantity shall commence from the last date of original delivery order and in cases where option clause is exercised during the extended delivery period the additional time shall commence from the last date of extended delivery period. The additional delivery time shall be $(\text{Increased quantity} \div \text{Original quantity}) \times \text{Original delivery period (in days)}$, subject to minimum of 30 days. If the original delivery period is less than 30 days, the additional time equals the original delivery period. The Purchaser may extend this calculated delivery duration up to the original delivery period while exercising the option clause. Bidders must comply with these terms.

2. **Generic**

After award of contract – Successful Bidder shall have to get Detailed Design Drawings approved from buyer before starting fabrication. Successful Bidder shall submit Detailed Design Drawings for Buyer's approval, within 5 days of award of contract. Buyer shall, either approve the drawings or will provide complete list of modification required in the drawings within 7 days. Seller shall be required to ensure supply as per approved Drawings with modifications as communicated by Buyer. If there is delay from buyer side in approval of drawing– the delivery period shall be refixed without LD for the period of delay in approval of Drawing.

3. **Generic**

Bidder financial standing: The bidder should not be under liquidation, court receivership or similar proceedings, should not be bankrupt. Bidder to upload undertaking to this effect with bid.

4. **Generic**

Bidders are advised to check applicable GST on their own before quoting. Buyer will not take any responsibility in this regards. GST reimbursement will be as per actuals or as per applicable rates (whichever is lower), subject to the maximum of quoted GST %.

5. **Generic**

Bidder shall submit the following documents along with their bid for Vendor Code Creation:

- a. Copy of PAN Card.
- b. Copy of GSTIN.
- c. Copy of Cancelled Cheque.
- d. Copy of EFT Mandate duly certified by Bank.

6. **Generic**

Data Sheet of the product(s) offered in the bid, are to be uploaded along with the bid documents. Buyers can match and verify the Data Sheet with the product specifications offered. In case of any unexplained mismatch of technical parameters, the bid is liable for rejection.

7. **Generic**

Experience Criteria: The Bidder or its OEM {themselves or through reseller(s)} should have regularly, manufactured and supplied same or similar Category Products to any Central / State Govt Organization / PSU for 3 years before the bid opening date. Copies of relevant contracts to be submitted along with bid in support of having supplied some quantity during each of the year. In case of bunch bids, the primary product having highest value should meet this criterion.

8. **Generic**

Manufacturer Authorization: Wherever Authorised Distributors/service providers are submitting the bid, Authorisation Form /Certificate with OEM/Original Service Provider details such as name, designation, address, e-mail Id and Phone No. required to be furnished along with the bid

9. **Generic**

Supplier shall ensure that the Invoice is raised in the name of Consignee with GSTIN of Consignee only.

10. **Generic**

1. The Seller shall not assign the Contract in whole or part without obtaining the prior written consent of buyer.
2. The Seller shall not sub-contract the Contract in whole or part to any entity without obtaining the prior written consent of buyer.

3. The Seller shall, notwithstanding the consent and assignment/sub-contract, remain jointly and severally liable and responsible to buyer together with the assignee/ sub-contractor, for and in respect of the due performance of the Contract and the Sellers obligations there under.

11. **Generic**

Without prejudice to Buyer's right to price adjustment by way of discount or any other right or remedy available to Buyer, Buyer may terminate the Contract or any part thereof by a written notice to the Seller, if:

- i) The Seller fails to comply with any material term of the Contract.
- ii) The Seller informs Buyer of its inability to deliver the Material(s) or any part thereof within the stipulated Delivery Period or such inability otherwise becomes apparent.
- iii) The Seller fails to deliver the Material(s) or any part thereof within the stipulated Delivery Period and/or to replace/rectify any rejected or defective Material(s) promptly.
- iv) The Seller becomes bankrupt or goes into liquidation.
- v) The Seller makes a general assignment for the benefit of creditors.
- vi) A receiver is appointed for any substantial property owned by the Seller.
- vii) The Seller has misrepresented to Buyer, acting on which misrepresentation Buyer has placed the Purchase Order on the Seller.

12. **Generic**

While generating invoice in GeM portal, the seller must upload scanned copy of GST invoice and the screenshot of GST portal confirming payment of GST.

13. **Scope of Supply**

Scope of supply (Bid price to include all cost components) : Only supply of Goods

14. **Purchase Preference (Centre)**

Purchase preference to Micro and Small Enterprises (MSEs): Purchase preference will be given to MSEs as defined in Public Procurement Policy for Micro and Small Enterprises (MSEs) Order, 2012 dated 23.03.2012 issued by Ministry of Micro, Small and Medium Enterprises and its subsequent Orders/Notifications issued by concerned Ministry. If the bidder wants to avail the Purchase preference, the bidder must be the manufacturer of the offered product in case of bid for supply of goods. Traders are excluded from the purview of Public Procurement Policy for Micro and Small Enterprises. In respect of bid for Services, the bidder must be the Service provider of the offered Service. Relevant documentary evidence in this regard shall be uploaded along with the bid in respect of the offered product or service. If L-1 is not an MSE and MSE Seller (s) has/have quoted price within L-1+ 15% of margin of purchase preference /price band defined in relevant policy, such Seller shall be given opportunity to match L-1 price and contract will be awarded for percentage of 25% of total value.

15. **Purchase Preference (Centre)**

Purchase Preference linked with Local Content (PP-LC) Policy:

The bid clause regarding "Preference to Make In India products" stands modified in this bid and shall be governed by the PPLC Policy No. FP-20013/2/2017-FP-PNG dated 17.11.2020 issued by MoP&NG as amended up to date. Accordingly, bidders with Local Content less than or equal to 20% will be treated as "Non Local Supplier". The prescribed LC shall be applicable on the date of Bid opening. Sanctions on the bidders for false / wrong declaration or not fulfilling the Local Content requirement shall be as per the PPLC policy. Further following additional provisions are added in the certification and verification of local content provision of the Preference to Make in India clause:

- i. In case of foreign bidder, certificate from the statutory auditor or cost auditor of their own office or subsidiary in India giving the percentage of local content is also acceptable. In case office or subsidiary in India does not exist or Indian office/subsidiary is not required to appoint statutory auditor or cost auditor, certificate from practicing cost accountant or practicing chartered accountant giving the percentage of local content is also acceptable.
- ii. Along with Each Invoice: The local content certificate (issued by statutory auditor on behalf of procuring company) shall be submitted along with each invoice raised. However, the % of local content may vary with each invoice while maintaining the overall % of local content for the total

work/purchase of the pro-rata local content requirement. In case, it is not satisfied cumulatively in the invoices raised up to that stage, the supplier shall indicate how the local content requirement would be met in the subsequent stages.

- iii. The bidder shall submit an undertaking from the authorized signatory of bidder having the Power of Attorney along with the bid stating the bidder meets the mandatory minimum LC requirement and such undertaking shall become a part of the contract.

16. **Certificates**

Bidder's offer is liable to be rejected if they don't upload any of the certificates / documents sought in the Bid document, ATC and Corrigendum if any.

17. **Certificates**

Material Test Certificate Should Be Sent Along with The Supply. The Material Will Be Checked by Buyer's Lab & the Results of the Lab will be the Sole Criteria for Acceptance of the Item.

18. **Certificates**

The bidder is required to upload, along with the bid, all relevant certificates such as BIS licence, type test certificate, approval certificates and other certificates as prescribed in the Product Specification given in the bid document.

19. **Past Project Experience**

Proof for Past Experience and Project Experience clause: For fulfilling the experience criteria any one of the following documents may be considered as valid proof for meeting the experience criteria:a. Contract copy along with Invoice(s) with self-certification by the bidder that service/supplies against the invoices have been executed.b. Execution certificate by client with contract value.c. Any other document in support of contract execution like Third Party Inspection release note, etc.**Proof for Past Experience and Project Experience clause:** For fulfilling the experience criteria any one of the following documents may be considered as valid proof for meeting the experience criteria:a. Contract copy along with Invoice(s) with self-certification by the bidder that service/supplies against the invoices have been executed.b. Execution certificate by client with contract value.c. Any other document in support of contract execution like Third Party Inspection release note, etc.

20. **Past Project Experience**

The Bidder / OEM {themselves or through reseller(s)}, should have executed project for supply and installation / commissioning of same or similar Category Products during preceding 3 financial years (i.e. current year and three previous financial years) as on opening of bid, as per following criteria:

- (i) Single order of at least 35% of estimated bid value; or
- (ii) Two orders of at least 20% each of estimated bid value; or
- (iii) Three orders of at least 15% each of estimated bid value.

Satisfactory Performance certificate issued by respective Buyer Organization for the above Orders should be uploaded with bid. In case of bunch bids, the Category related to primary product having highest bid value should meet this criterion

21. **Buyer Added Bid Specific ATC**

Buyer Added text based ATC clauses

NOTE:

· ACCEPATBLE DELIVERY PERIOD IS 2-3 MONTHS FROM THE DATE OF PLACEMENT OF PURCHASE ORDER.

· DRAWING AND QAP SHALL BE SUBMITTED FOR APPROVAL PRIOR TO COMMENCEMENT OF MANUFACTURING. THE QAP SHALL BE PREPARED IN ACCORDANCE WITH EIL SPEC NO. 6-17-0007 REV.5 (ATTACHED).

ALL CERTIFICATES, INCLUDING RADIOGRAPHY (LEVEL 2), CHEMICAL AND MECHANICAL TEST CERTIFICATES, ETC., AS PER EIL SPEC NO. 6-17-0007 REV. 5, SHALL BE SUBMITTED ALONG WITH THE SUPPLY.

THIRD PARTY INSPECTION : PLEASE NOTE THAT THIRD PARTY INSPECTION WILL BE APPLICABLE IN THIS PROCUREMENT. YOU SHALL INTIMATE US WHEN THE ITEMS ARE READY. WE WILL ARRANGE FOR THIRD PARTY INSPECTION (TPI) OF MATERIALS THROUGH OUR APPROVED TPI AGENCY.

MATERIALS WILL HAVE TO BE INSPECTED AT THE VENDOR'S WORKS PRIOR TO DESPATCH AND SHALL BE DESPATCHED ONLY AFTER THE INSPECTION & APPROVAL BY THE TPI. THE INSPECTION WITNESSING CHARGES TO THE THIRD PARTY SHALL BE BORNE BY HOCL AS PER HOCL'S AGREEMENT WITH THE THIRD PARTY. HOWEVER WHATEVER COST INCURRED FOR INSPECTION OF MATERIAL (LIKE NDT ETC.) SHOULD BE BORNE BY THE SUPPLIER. HENCE AS PER THE GEM TENDER TERMS THE RATE QUOTED SHALL BE ALL INCLUSIVE. INSPECTION OF THE MATERIAL WILL BE CONDUCTED ON A MUTUALLY AGREED DATE AFTER THE COMPLETION OF MANUFACTURING AND NECESSARY TESTING. ANY DEVIATIONS OR NON-CONFORMITIES IDENTIFIED DURING THE INSPECTION MUST BE CORRECTED BY THE VENDOR. A RE-INSPECTION WILL BE CONDUCTED ON A MUTUALLY AGREED DATE TO VERIFY THE CORRECTIONS. COST OF THE RE-INSPECTION INCURRED TO HOCL AS THIRD PARTY INSPECTION COST SHALL BE BORNE BY THE VENDOR . PLEASE NOTE THAT THE ITEM WILL BE FINAL ACCEPTED ONLY AFTER INSPECTION AND APPROVAL BY OUR DESIGNATED ENGINEER AT THE HOCL SITE.

DRAWINGS ATTACHED.

THESE ITEMS ARE REQUIRED FOR ANNUAL SHUTDOWN WORKS. HENCE THE SUPPLIER SHOULD STRICTLY ADHERE TO THE DELIVERY PERIOD . ALL THE PROCESSES LIKE DRAWING APPROVAL, THIRD PARTY INSPECTION AND DISPATCHING OF THE MATERIAL ETC SHOULD BE COMPLETED WITHIN THE OFFERED DELIVERY PERIOD.

1. Specification sheet, Commercial term formats, Bid security declaration, Compliance of land border as per given annexures should be filled , signed and submitted along with the offer. If any deviation, please mention separately.

2. ARBITRATION OF DISPUTES:- All disputes, differences, questions and claims arising out of, under or touching upon this Tender /Agreement/ Purchase Order/ Work Order shall be settled amicably between the parties through mutual discussion. If the parties fail to resolve the dispute by such mutual consultation within 21 days, then such disputes, difference, questions or claims shall be referred for resolution through arbitration by either of the parties to the India International Arbitration Centre or a Sole Arbitrator mutually agreed upon by the parties from a panel of arbitrators. The award of Arbitration shall be final and binding on the parties. The seat of the Arbitration shall be at Kochi, Kerala, India and the proceedings of the arbitration shall be held at Kochi, Kerala, India in accordance with the India International Arbitration Centre Act 2019 / Indian Arbitration & Conciliation Act 1996 or any statutory modification or re-enactment thereof for the time being in force. When the contract is with foreign vendor, the vendor has the option to choose arbitration in accordance with the provisions of The India International Arbitration Centre Act 2019 / The Indian Arbitration and Conciliation Act, 1996 / UNCITRAL (United Nations Commission on International Trade Law Arbitration/Arbitration Rules."

3. GENERAL INFORMATION TO SUPPORT THE GROWTH OF MSME BUSINESS " The Government of India offers two excellent opportunities to elevate the quality and sustainability of MSME businesses—the ZED Certification (Zero Defect Zero Effect) and the MSME Competitive (Lean) Scheme—both designed to improve product quality, enhance competitiveness, and provide access to government benefits." Eligible MSMEs shall apply through online portal : <https://zed.msme.gov.in/> <https://lean.msme.gov.in/>

22. Buyer Added Bid Specific ATC

Buyer uploaded ATC document [Click here to view the file.](#)

23. Inspection

Nominated Inspection Agency: On behalf of the Buyer organization, any one of the following Inspection Agency would be conducting inspection of stores before acceptance:
Pre-dispatch Inspection at Seller Premises (applicable only if pre-dispatch inspection clause has been selected in ATC):

M/S. ICS INDIA PVT LTD.

Post Receipt Inspection at consignee site before acceptance of stores:
M/S. HOCL

अस्वीकरण/Disclaimer

The Additional Terms and Conditions (ATC) have been incorporated by the Buyer after approval of their Competent Authority. The Buyer, is solely responsible for the impact of these clauses on the bidding process, its outcome, and consequences thereof including any restriction arising in the bidding process due to these ATCs and including the modification of technical specifications and / or terms and conditions governing the bid. All representations / grievances pertaining to the ATC clauses shall be raised with the buyer organization directly and not with GeM. If any of the clause(s) is/are incorporated by the Buyer regarding the following, the bid & resultant contract shall be treated as null & void. Further, GeM reserves the right, at its sole discretion, to cancel the bid forthwith, without issuance of any prior notice or intimation :-

1. Publishing Custom / BOQ bids for items for which regular GeM categories are available (unless such Custom / BOQ item is bunched with the major regular product Category Item).
2. Mandating procurement of / from specific Brand / Make / Model / Manufacturer / Dealer except in case of Single Bid / Proprietary Article Certificate (PAC) Buying.
3. Inclusion of disqualification criteria related to suspension of seller / service provider, where such suspension period has already expired.
4. Mandating submission of documents in physical form as a pre-requisite to qualify bidders.
5. Publishing bids on GeM for procurement of works.
6. Procurement of Goods by creating a Service bid on GeM & vice-versa.
7. Seeking sample with bid or approval of samples during bid evaluation process. However, trial / sample, as the case may be, shall be permitted in cases where trial / sample are allowed as per approved and published procurement policy of the Buyers' controlling Ministry / Department / State / Public Sector Enterprises Headquarters. If there is any violation of trial / sample clause with regard to approved policy of the Buyers' Ministry / Department / State / Public Sector Enterprises Headquarters, then this is to be determined and redressed by the concerned Buyer Organisation only.
8. Seeking experience from specific organization / department / institute only or from foreign / export experience.
9. Creating bid for items from incorrect categories.
10. Reference of conditions published on any external site or reference to external documents/clauses.
11. Asking for any Tender fee / Bid Participation fee, as the case may be.
12. Buyer added ATC Clauses which are in contravention of clauses defined in bid detail section, including specifications, EMD Detail, ePBG Detail and MII and MSE Purchase Preference sections of the bid, unless otherwise allowed by the applicable GeM GTC.
13. Any ATC clause in contravention with GeM GTC Clause 4 (xiii) (h) will be invalid. In case of multiple L1 bidders against a service bid, the buyer shall place the Contract by selection of a bidder amongst the L-1 bidders through a Random Algorithm executed by GeM system.
14. In a category based bid, adding additional items, through buyer added, additional scope of work/ additional terms and conditions/or any other document. If buyer needs more items along with the main item, the same must be added through bunching category based items or by bunching custom catalogues or bunching a BoQ with the main category based item, the same must not be done through ATC or Scope

of Work.

Further, if any seller has any objection/grievance against these additional clauses or otherwise on any aspect of this bid, they can raise their representation against the same by using the Representation window provided in the bid details field in Seller dashboard after logging in as a seller. Buyer is duty bound to reply to all such representations and would not be allowed to open bids if he fails to reply to such representations.

All GeM Sellers/Service Providers shall ensure full compliance with all applicable labour laws, including the provisions, rules, schemes and guidelines under the four Labour Codes i.e. the Code on Wages, 2019; the Industrial Relations Code, 2020; the Occupational Safety, Health and Working Conditions Code, 2020; and the Code on Social Security, 2020 as and when notified and brought into force by the Government of India.

For all provisions of the Labour Codes that are pending operationalisation through rules, schemes or notifications, the corresponding provisions of the pre-existing labour enactments (such as The Minimum Wages Act, 1948, The Payment of Wages Act, 1936, The Payment of Bonus Act, 1965, The Equal Remuneration Act, 1976, The Payment of Gratuity Act, 1972, etc. and relevant State Rules) shall continue to remain applicable.

The Seller/ Service Providers shall, therefore, be responsible for ensuring compliance under:

- **All notified and enforceable provisions of the new Labour Codes as mentioned hereinabove; and**
- **All operative provisions of the erstwhile Labour Laws until their complete substitution.**

All obligations relating to wages, social security, safety, working conditions, industrial relations etc. and any other statutory requirements shall be strictly met by the Seller/ Service Provider. Any non-compliance shall constitute a breach of the contract and shall entitle the Buyer to take appropriate action in accordance with the contract and applicable law.

This Bid is governed by the General Terms and Conditions, conditions stipulated in Bid and Service Level Agreement specific to the Service, as the case may be, as provided in the Marketplace.

However, in case of Service, if any condition specified in General Terms and Conditions is contradicted by the conditions stipulated in Service Level Agreement specific to said Service, then it will over-ride the conditions in the General Terms and Conditions.

[यह बिड सामान्य शर्तों के अंतर्गत भी शासित है /This Bid is also governed by the General Terms and Conditions](#)

जेम की सामान्य शर्तों के खंड 26 के संदर्भ में भारत के साथ भूमि सीमा साझा करने वाले देश के बिडर से खरीद पर प्रतिबंध के संबंध में भारत के साथ भूमि सीमा साझा करने वाले देश का कोई भी बिडर इस निविदा में बिड देने के लिए तभी पात्र होगा जब वह बिड देने वाला सक्षम प्राधिकारी के पास पंजीकृत हो। बिड में भाग लेते समय बिडर को इसका अनुपालन करना होगा और कोई भी गलत घोषणा किए जाने व इसका अनुपालन न करने पर अनुबंध को तत्काल समाप्त करने और कानून के अनुसार आगे की कानूनी कार्रवाई का आधार होगा।/In terms of GeM GTC clause 26 regarding Restrictions on procurement from a bidder of a country which shares a land border with India, any bidder from a country which shares a land border with India will be eligible to bid in this tender only if the bidder is registered with the Competent Authority. While participating in bid, Bidder has to undertake compliance of this and any false declaration and non-compliance of this would be a ground for immediate termination of the contract and further legal action in accordance with the laws.

---धन्यवाद/Thank You---



हिंदुस्तान ऑर्गेनिक केमिकल्स लिमिटेड HINDUSTAN ORGANIC CHEMICALS LTD

(भारत सरकार का उद्यम A Government of India Enterprise)

अंबलमुगल, कोची AMBALAMUGAL, COCHIN – 682 302

दूर भाष Phone: (0484) 2720911

विनिर्देशन प्रपत्र SPECIFICATION SHEET

आइटम नंबर Item Number	आइटम विवरण Item Description	वस्तु की मात्रा Item Quantity	माप की इकाई Unit of Measure
1	RADIANT SECTION WALL TUBE HANGER AS PER DRG NO. 7-17-0118 REV.7. MANUFACTURING STANDARD, DIMENSIONAL TOLERANCES, QUALITY CONTROL, INSPECTION, TESTING & GUARANTEE ETC. SHALL COMPLY AS PER EIL SPEC NO. 6-17-0007 REV.5 MOC : A351 GR. HK40 (25Cr - 20Ni)	136	NOS.
2	ARCH SECTION TUBE HANGER AS PER DRG NO. HOC/MECH/F6001/TUBE HANGER/ARCH SEC. MANUFACTURING STANDARD, DIMENSIONAL TOLERANCES, QUALITY CONTROL, INSPECTION, TESTING & GUARANTEE ETC. SHALL COMPLY AS PER EIL SPEC NO. 6-17-0007 REV.5 MOC : A351 GR. HK40 (25Cr - 20Ni)	4	NOS.
3	CONVECTION SECTION TUBE HANGER AS PER DRG NO. HOC/MECH/F6001/TUBE HANGER/CONVECTION SEC. MANUFACTURING STANDARD, DIMENSIONAL TOLERANCES, QUALITY CONTROL, INSPECTION, TESTING & GUARANTEE ETC. SHALL COMPLY AS PER EIL SPEC NO. 6-17-0007 REV.5 MOC : A351 GR. HK40 (25Cr - 20Ni)	4	NOS.
4	HINGE PIN FOR ARCH & CONVECTION SECTION TUBE HANGER AS PER DRG NO. HOC/MECH/F6001/HINGE PIN FOR TUBE HANGER MANUFACTURING STANDARD, DIMENSIONAL TOLERANCES, QUALITY CONTROL, INSPECTION, TESTING & GUARANTEE ETC. SHALL COMPLY AS PER EIL SPEC NO. 6-17-0007 REV.5 MOC : A351 GR. HK40 (25Cr - 20Ni)	8	NOS.
5	SUPPORTING PLATE FOR CONVECTION SECTION TUBE HANGER AS PER DRG NO. HOC/MECH/F6001/SUPPORTING PLATE FOR TUBE HANGER MANUFACTURING STANDARD, DIMENSIONAL TOLERANCES, QUALITY CONTROL, INSPECTION, TESTING & GUARANTEE ETC. SHALL COMPLY AS PER EIL SPEC NO. 6-17-0007 REV.5 MOC : A351 GR. HK40 (25Cr - 20Ni)	4	Nos

NOTE:

- ACCEPATBLE DELIVERY PERIOD IS 2-3 MONTHS FROM THE DATE OF PLACEMENT OF PURCHASE ORDER.
- DRAWING AND QAP SHALL BE SUBMITTED FOR APPROVAL PRIOR TO COMMENCEMENT OF MANUFACTURING. THE QAP SHALL BE PREPARED IN ACCORDANCE WITH EIL SPEC NO. 6-17-0007 REV.5 (ATTACHED).

- ALL CERTIFICATES, INCLUDING RADIOGRAPHY (LEVEL 2), CHEMICAL AND MECHANICAL TEST CERTIFICATES, ETC., AS PER EIL SPEC NO. 6-17-0007 REV. 5, SHALL BE SUBMITTED ALONG WITH THE SUPPLY.
- THIRD PARTY INSPECTION : PLEASE NOTE THAT THIRD PARTY INSPECTION WILL BE APPLICABLE IN THIS PROCUREMENT. YOU SHALL INTIMATE US WHEN THE ITEMS ARE READY. WE WILL ARRANGE FOR THIRD PARTY INSPECTION (TPI) OF MATERIALS THROUGH OUR APPROVED TPI AGENCY.
- MATERIALS WILL HAVE TO BE INSPECTED AT THE VENDOR'S WORKS PRIOR TO DESPATCH AND SHALL BE DESPATCHED ONLY AFTER THE INSPECTION & APPROVAL BY THE TPI. THE INSPECTION WITNESSING CHARGES TO THE THIRD PARTY SHALL BE BORNE BY HOCL AS PER HOCL'S AGREEMENT WITH THE THIRD PARTY. HOWEVER WHATEVER COST INCURRING FOR INSPECTION OF MATERIAL (LIKE NDT ETC.) SHOULD BE BORNE BY THE SUPPLIER. HENCE AS PER THE GEM TENDER TERMS THE RATE QUOTED SHALL BE ALL INCLUSIVE. INSPECTION OF THE MATERIAL WILL BE CONDUCTED ON A MUTUALLY AGREED DATE AFTER THE COMPLETION OF MANUFACTURING AND NECESSARY TESTING. ANY DEVIATIONS OR NON-CONFORMITIES IDENTIFIED DURING THE INSPECTION MUST BE CORRECTED BY THE VENDOR. A RE-INSPECTION WILL BE CONDUCTED ON A MUTUALLY AGREED DATE TO VERIFY THE CORRECTIONS. COST OF THE RE-INSPECTION INCURRED TO HOCL AS THIRD PARTY INSPECTION COST SHALL BE BORNE BY THE VENDOR. PLEASE NOTE THAT THE ITEM WILL BE FINAL ACCEPTED ONLY AFTER INSPECTION AND APPROVAL BY OUR DESIGNATED ENGINEER AT THE HOCL SITE.
- DRAWINGS ATTACHED.
- THESE ITEMS ARE REQUIRED FOR ANNUAL SHUTDOWN WORKS. HENCE THE SUPPLIER SHOULD STRICTLY ADHERE TO THE DELIVERY PERIOD. ALL THE PROCESSES LIKE DRAWING APPROVAL, THIRD PARTY INSPECTION AND DISPATCHING OF THE MATERIAL ETC SHOULD BE COMPLETED WITHIN THE OFFERED DELIVERY PERIOD.

फायर्ड हीटर के लिए
ट्यूब सपोर्ट कास्टिंग्स हेतु
मानक विनिर्देश

STANDARD SPECIFICATION OF
TUBE SUPPORT CASTINGS FOR
FIRED HEATERS

5	03.04.17	REVISED AND ISSUED AS STANDARD SPECIFICATION	RKM	RP/AP	RKT	RN
4	19.01.11	REVISED AND ISSUED AS STANDARD SPECIFICATION	MK	KJHN/DK	AKG	ND
3	07.02.06	REVISED AND ISSUED AS STANDARD SPECIFICATION	AB	DK	AKG	VJN
Rev. No	Date	Purpose	Prepared by	Checked by	Standards Committee Convenor	Standards Bureau Chairman
						Approved by

Abbreviations:

API	:	American Petroleum Institute
ASME	:	American Society for Mechanical Engineers
ASTM	:	American Society for Testing and Materials
Cb	:	Columbium
Cr	:	Chromium
DP	:	Dye Penetrant
IS	:	Indian Standard
ITP	:	Inspection and Test Plan
MP	:	Magnetic Particle
MSS	:	Manufacturer's Standards Society
Nb	:	Niobium
Ni	:	Nickel
SP	:	Standard Practice
UIN	:	Unique Identification Number

Fired Equipment Standards Committee

Convener: Mr. R.K. Trivedi

Members: Mr. Mandip Kapoor
Mr. Amit Prakash
Mr. Rajesh Patel
Mr. Deepak Gupta (Projects)
Mr. D. Jana (Construction)

CONTENTS

1.0	SCOPE	4
2.0	MATERIAL	4
3.0	GENERAL REQUIREMENTS	4
4.0	MANUFACTURE	5
5.0	DIMENSIONAL TOLERANCES	5
6.0	QUALITY CONTROL, INSPECTION AND TESTING.....	5
7.0	REPAIRS	7
8.0	GUARANTEE	7
9.0	PACKING, PRESERVATION AND SHIPMENT	8

1.0 SCOPE

- 1.1 This specification covers the minimum requirements for manufacturing, inspection and testing for static type tube support castings for high temperature non-pressure part service in fired heaters. These castings can be in the form of hangers, brackets, lugs, guides, spacers, beams, tube sheets etc.

2.0 MATERIAL

- 2.1 Material of castings shall be as specified in the requisition, the respective drawings and the relevant ASTM specifications.
- 2.2 For castings as per ASTM specifications A297, A351 and A447, the chemical composition should be controlled in such a way that the Ferrite content (determined as per ASTM A800 / 800M) is not more than 20%.
- 2.3 In case of 19Cr-9Ni castings the Delta Ferrite content shall be limited to maximum of 6%. For 19Cr-9Ni castings which will be subject to welding, either by the Purchaser (if specified in the requisition) or by Supplier (for permitted repairs), the Delta Ferrite content shall be controlled to within a range of 3-6%. For all cases, the microstructure should also not reveal any delta ferrite network along the grain boundary.
- 2.4 50Cr-50Ni castings to ASTM specification A560 shall be Cb/Nb stabilized type.

3.0 GENERAL REQUIREMENTS

3.1 Trial Assembly

- 3.1.1 Supplier shall trial assemble all mating parts as defined in the requisition, prior to dispatch.
- 3.1.2 Special care like group trial assembly and unique identification number with match marking shall be stenciled in paint for ladder type tube supports, so that each ladder with side bars and cross-bars is uniquely identified. Similarly, tube spacers for multiple tubes shall be trial assembled at shop as per purchaser assembly drawing and UIN with match marking shall be provided after correct alignment. The marking drawing with UIN shall be supplied along with the dispatch documents.
- 3.1.3 Castings, wherever specified in requisition shall be supplied along with machining / threading on the specified area. In case of threaded castings where matching nuts are not in casting Supplier's scope of supply and are being procured independently by the Purchaser, the trial assembly shall be carried out using sample nuts either supplied or approved by the Purchaser.
- 3.2 All castings shall have pattern numbers cast in the location indicated in the drawing.
- 3.3 The manufacture and testing of the castings shall be in accordance with the relevant specifications stated in the requisition. In case any requirement of this specification does not match the requirement laid down in the relevant ASTM Specification for the casting, the more stringent requirement shall govern.
- 3.4 For austenitic steel castings, tools and shot-blasting materials shall be free from Ferrite content.
- 3.5 The grinding discs and marking materials used for castings shall be free from harmful materials like Phosphorous, Lead, Sulphur, Vanadium, Halogens, Aluminum and Zinc etc.

4.0 MANUFACTURE

- 4.1 Location of risers to be decided carefully ensuring that there is no hindrance in the intended function of the casting. The same shall be submitted for information.
- 4.2 All fillets, rounds, tube holes, horizontal rib / flange edges shall be chamfered or rounded off to minimum 6 mm radius unless otherwise noted.
- 4.3 All tube bearing surfaces shall be cast smooth and without draft for 30 degree each side of vertical centerline.
- 4.4 All holes shall be cored. For holes upto 32 mm diameter, drilling may also be accepted, provided casting remains unaffected in all respects.

5.0 DIMENSIONAL TOLERANCES

- 5.1 Following tolerance are allowed for the finished casting, unless otherwise noted on drawings :

- Thickness	:	+ 3 mm, - 0 mm
- Tube hole diameter	:	± 1.5 mm
- C/c tube hole spacing in all directions	:	± 1.5 mm between adjacent holes but max. ± 3 mm between extreme holes
- Dimensions upto 500 mm	:	± 2 mm
- Dimensions above 500 & upto 3000 mm	:	± 5 mm
- Dimensions over 3000 mm	:	± 7.5 mm
(For Intermediate Tube Sheet tolerances shall be limited to ± 5 mm)		
- Deflections & misalignments of tube supporting surfaces	:	± 2 mm
- Surfaces and buckling defects	:	± 2 mm
- Twist and warp	:	3 mm / meter (non-cumulative, max. 5 mm)

- 5.2 IS: 4897 Class 2 shall be applicable for “untoleranced Dimensions” only.

6.0 QUALITY CONTROL, INSPECTION AND TESTING

- 6.1 Vendor shall submit ITP for approval by authorized Inspection Agency.
- 6.2 Vendor to produce pilot casting for each pattern and carry out the necessary destructive / non-destructive tests as required, to ensure that the foundry procedures are satisfactory and the castings produced meet the requirements of the requisition and relevant ASTM Specifications.
- 6.3 **Dimensional Check**
- 6.3.1 All the castings shall be checked by the Supplier for compliance to the dimensions laid down in the drawings and records to be furnished to Inspector for endorsement. The tolerances shall be strictly within the limits laid down in this specification. The Inspector shall carry out a comprehensive dimensional check on the pilot casting and 5% of the production castings randomly selected, subject to a minimum of 5 nos. In case the results are found unsatisfactory, the Inspector shall decide on the extent of further checks or the complete lot is liable to be rejected.

6.4 External Condition

- 6.4.1 Tube supports shall be adequately cleaned to facilitate examination of all surfaces.
- 6.4.2 Visual checking shall be carried out on all surfaces to reveal surface defects. Surface condition of castings shall be visually examined in accordance with MSS SP 55. Further testing, if required to ensure quality, shall be decided by the Inspector.
- 6.4.3 Surface of castings shall be dye penetrant checked using E 165. Acceptance shall be in accordance with E 433 standard reference photographs. For pilot castings the DP check shall be carried out on complete areas. DP check on production castings shall be decided by the Inspector and shall include critical areas like intersection of ribs with main member, bearing surfaces, bottom flange of beams / tube-sheets etc. The defective areas shall require a radiographic examination.
- 6.4.4 In case of ferritic castings, magnetic permeability check as per E 709 shall be carried out instead of dye penetrant examination.
- 6.4.5 Cracks and fissures (determined by DP check / MP inspection / insertion of metal wire etc.) which are within limits defined hereunder may be repaired by welding after proper surface preparation. Defects beyond these limits are unacceptable and such defective castings shall be rejected.
- Depth : 1/5 th of the thickness or 10 mm, whichever is less
 - Length : 50 mm at support areas and 100 mm at other locations
 - Distance between two cracks / fissures shall not be less than 10 times the rib thickness.

6.5 Internal Condition

- 6.5.1 Castings may be slightly hammered to find out blisters and cavities etc. if any.
- 6.5.2 Castings shall be radiographed in accordance with ASTM Specification E 94. The following radiography criteria shall be applicable to determine the internal condition of castings and meet the requirements of ASTM specifications:

- Upto 2" thickness : Reference radiographs as per E 446
- 2" to 4" thickness : Reference radiographs as per E 186

The minimum acceptance level shall be :

- Level 2 : For castings like hangers, lugs etc.
For critical areas like support areas and bottom flanges of beams and tube-sheets
- Level 3 : All other castings / areas

- 6.5.3 All pilot castings shall be subject to 100% radiography. The extent of radiographic examination on production castings shall be as given below:

- Tube-sheets, beams and ladder support side bars : Indicated areas for each casting as shown on the drawings
- Other castings including ladder support cross bars : 100% radiography on 5% of each type production casting (min. 2 per pattern)

In case of unsatisfactory results in radiography of production castings, another set of castings equal to 2 times the initial sample size shall be examined by radiography. If any unsatisfactory results are observed on the additional samples then the entire lot would be either rejected or if decided by the Inspector, radiography conducted on all the pieces of the offered lot.

6.6 Chemical and Mechanical Tests

- 6.6.1 Chemical analysis and mechanical tests shall be carried out on test pieces for each heat in accordance with the relevant ASTM Specification.
- 6.6.2 Test pieces shall be cast integral with the casting. However, if necessary, separately cast test bars may be allowed subject to approval of the inspector. Test pieces / test bars are to be stamped by the Inspector for identification.
- 6.6.3 Unless otherwise instructed, the tests shall be carried out in the presence of the Inspector and test results are to be submitted to the Inspector.
- 6.6.4 One tension test for each melt is compulsory.
- 6.6.5 A high temperature tensile test would need to be conducted on a test sample, in case specified in the requisition. Failure to meet the required stress values, would lead to rejection of the castings.
- 6.6.6 Vendor shall conduct the following tests for each heat for ASTM A447 castings :
- Magnetic Permeability Test
 - Stress Rupture Test
- 6.7 Positive Material Identification shall be carried out on all the tube sheet & ladder side bar castings and min. 10% of the other castings chosen at random by the Inspector.

7.0 REPAIRS

- 7.1 No repair activity is permitted without prior permission from the Inspector. Vendor shall prepare a qualified procedure for all repairs in accordance with ASME Section IX. The Repair Procedure shall be submitted and approved by Inspector before any repairs are undertaken.
- 7.2 Small surface defects may be remedied by milling or grinding followed by verification by DP examination, subject to tolerances as permitted in this specification.
- 7.3 No major repair is permitted on castings / areas where Level 2 of radiography acceptance is applicable.
- 7.4 For repair by welding, the composition of the deposited weld metal shall be similar to the composition of the casting.
- 7.5 Same defect shall not be repaired more than once.
- 7.6 All weld repairs shall be recorded and subjected to a dye penetrant examination. If the defect was detected by a radiographic examination, the weld repair shall be radiographed in addition.

8.0 GUARANTEE

- 8.1 Vendor shall guarantee API 560 stresses for the castings supplied. In case allowable stresses are specified in the requisition, same to be guaranteed. Vendor to mention the basis of stress guarantees in his Offer.

8.2 Vendor shall guarantee all castings supplied by him against defective / sub-standard material, poor workmanship etc.

9.0 PACKING, PRESERVATION AND SHIPMENT

9.1 All items shall be cleaned from testing agent residues and protected against rust from foreign sources, by appropriate covering. Storage in open air without protective cover is not permitted.

9.2 Due care shall be taken that slender items like ladder side bars, multiple tube guides etc. that are liable to deformation are stored on even surface and not subject to unnecessary loads.

9.3 All castings shall be marked with UIN.

9.4 The data folder to be submitted at time of dispatch shall contain casting drawings, casting procedure, chemical test results, mechanical test results, final weights of castings; Inspection Report duly witnessed by the Inspecting Authority and marked up drawing with UINs.

9.5 Vendor shall submit preservation procedure for the castings.

9.6 All castings shall be packed carefully and protected against any damage / deterioration during transit, handling and storage. The packing should be sea worthy (if imported). Packing shall be suitable for opening for dockside inspection.

TYPE	Ft
2	13

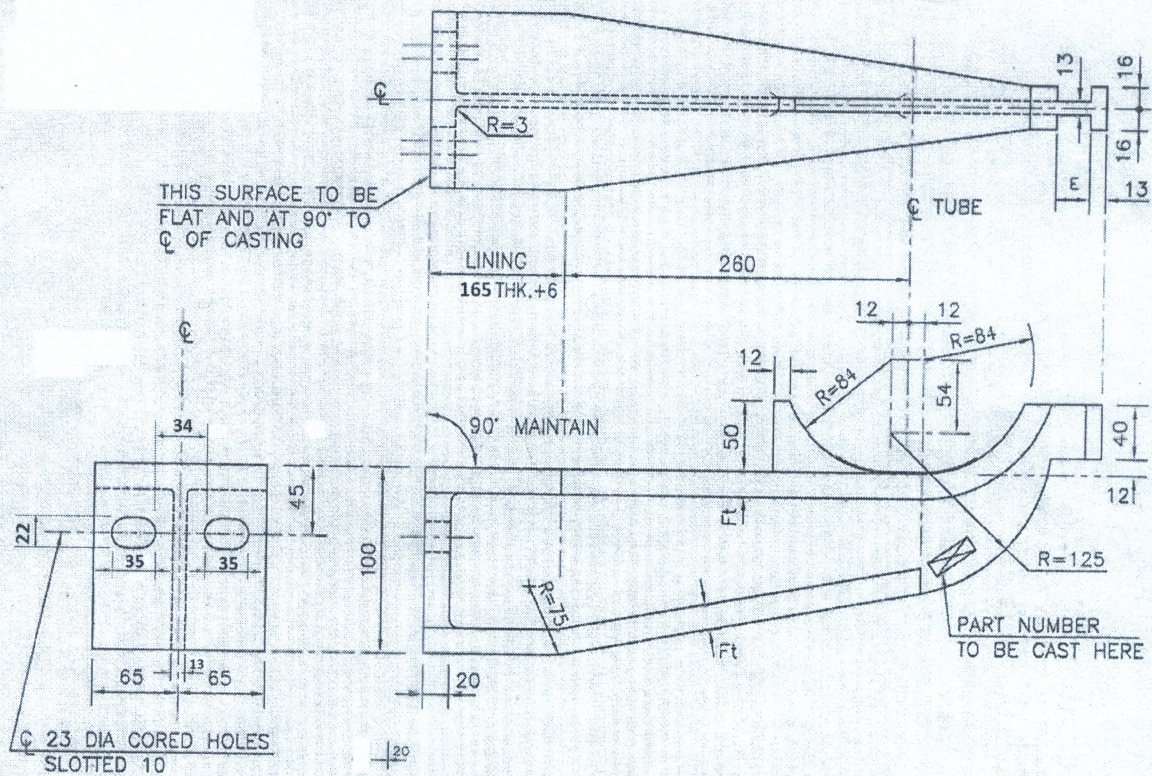

GENERAL NOTES:-

1. ALL DIMENSIONS ARE IN MILLIMETRES.
2. ALL FILLETS AND ROUNDS SHALL BE 6 RADIUS UNLESS OTHER WISE NOTED.
3. ALL TUBE BEARING SURFACES ARE TO BE CAST SMOOTH & PARALLEL FOR 30° EACH SIDE OF VERTICAL C. NO DRAUGHT.

4. TRIAL ASSEMBLY WITH LOCKING BARS SHALL BE ENSURED PRIOR TO DESPATCH.
5. THE VALUE OF E SHALL BE 25mm U.O.N. ON GENERAL ARRANGEMENT DWG.

COMPANION STANDARD:-

- FIXING DETAIL FOR WALL TUBE HANGER 7-17-0440
- LOCKING BAR FOR WALL TUBE SUPPORTS 7-17-0136 (4 TUBES)
- LOCKING BAR FOR WALL TUBE SUPPORTS 7-17-0137 (3 TUBES)
- LOCKING BAR FOR WALL TUBE SUPPORTS 7-17-0138 (2 TUBES)

Handwritten signature

Handwritten signature
CE(mlu)

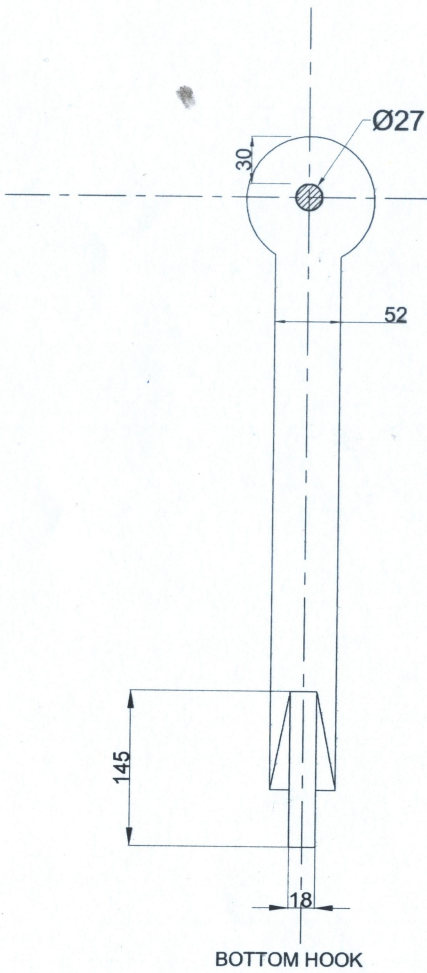

BOTTOM HOOK

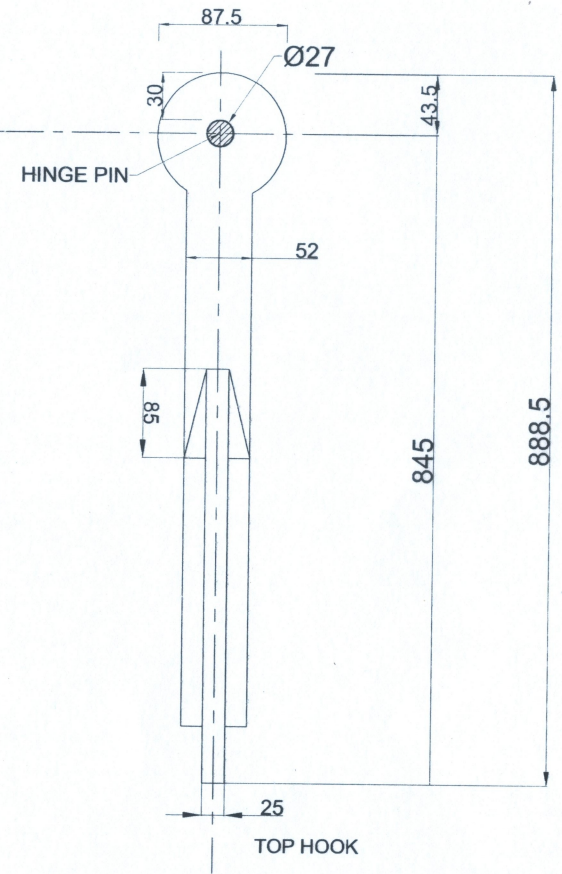
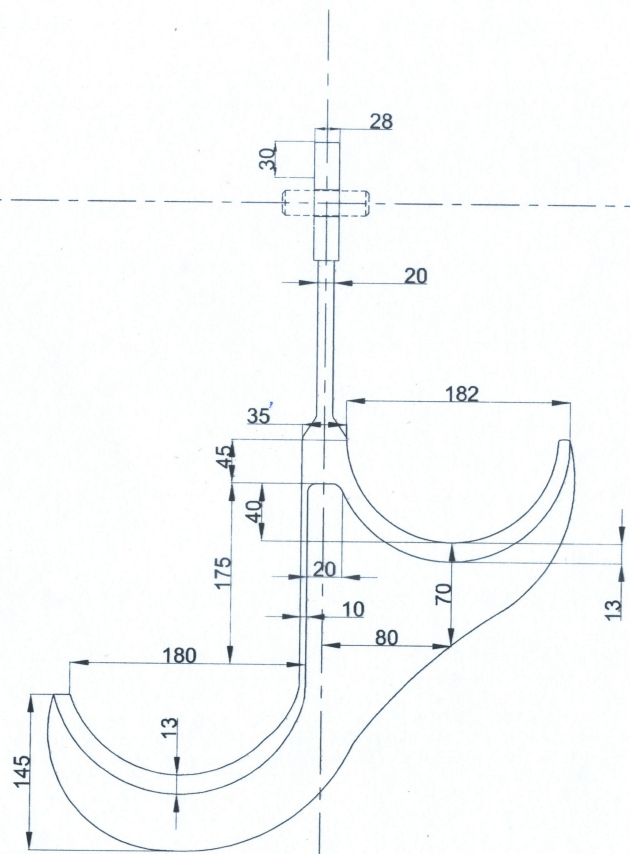

TOP HOOK

HINGE PIN - DRAWING

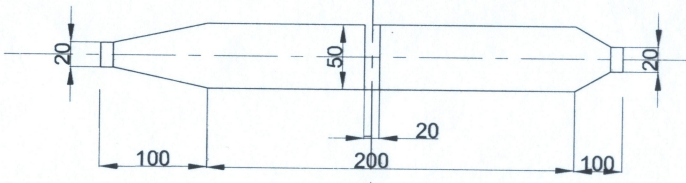
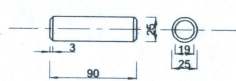

**CLAMP SHALL BE SUITABLE FOR SUPPORTING 6"xSCH40 PIPE
 **HINGE DIA SHALL BE SUITABLE FOR ACCOMODATING HINGE PIN DIA 25 MM.

**MOC: ASTM A351 GR. HK40 (25Cr - 20Ni)

ALL DIMENSIONS ARE IN MM

NO	ZONE	PARTICULARS	REVISION	REVISED	CHECKED	APPROVED	DATE	CHECKED	DATE	APPROVED

SCALE: NOT FOR SCALE
 DATE: 10/05/2026
 DRAWN: DM (MECH)
 CHECKED: [Signature]
 APPROVED: [Signature]
 TITLE: ARCH SECTION TUBE HANGER (HOT OIL HEATER - ARCH SECTION)
 SHEET 1 OF 1
 DRG. No. HOC/MECH/ F-6001-TUBE HANGER/ARCH SEC
 REV. 1

A1

HINGE PIN

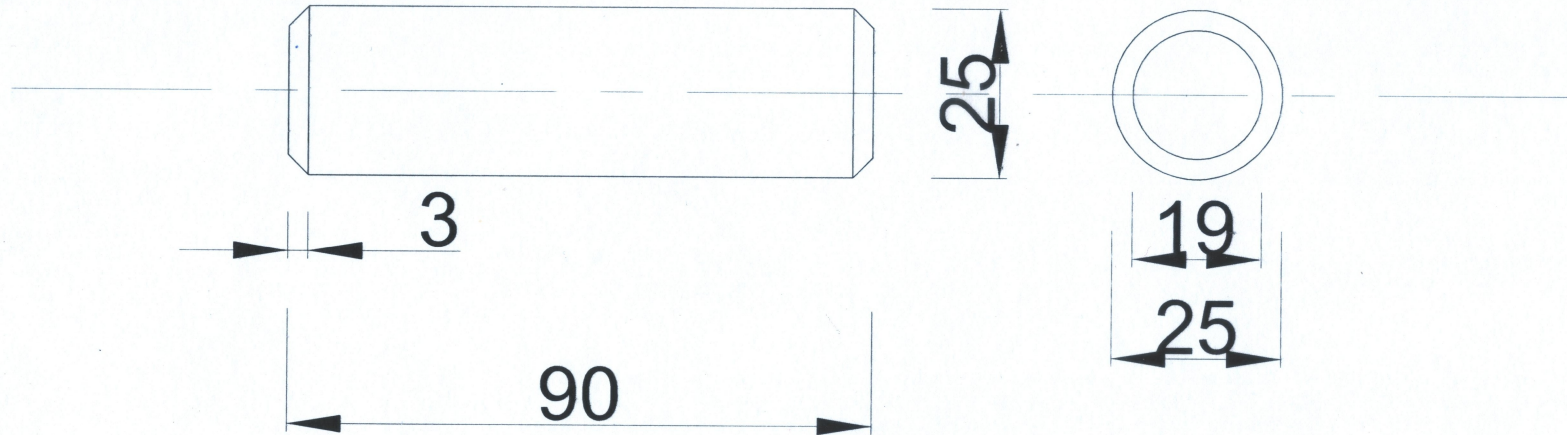

****MOC: ASTM A351 GR. HK40 (25Cr - 20Ni)**

ALL DIMENSIONS ARE
IN MM

SCALE	NOT FOR SCALE	HINDUSTAN ORGANIC CHEMICALS LTD.		
DATE	10/05/2026	AMBALAMUGAL KERALA		
DRWEN	DM (MECH)	TITLE		PIN FOR ARCH & CONVECTION SECTION TUBE HANGER FOR HOT OIL HEATER.
APPROVED	CE (MECH/UTY)	SHEET 1 OF 1		
NO	ZONE	PARTICULARS	REVISION	DRG. No. HOC/MECH/F-6001-HINGE PIN FOR TUBE HANGER
5				REV. 1

A1



हिंदुस्तान ऑर्गेनिक केमिकल्स लिमिटेड HINDUSTAN ORGANIC CHEMICALS LTD

(भारत सरकार का उद्यम A Government of India Enterprise)

अंबलमुगल, कोची AMBALAMUGAL, COCHIN – 682 302

दूर भाष Phone: (0484) 2720911

प्रिय महोदय Dear Sir,

हिंदुस्तान ऑर्गेनिक केमिकल्स लिमिटेड भारत सरकार का उपक्रम है जो कोच्चि, केरल, भारत में अपने संयंत्र में फीनोल, एसीटोन और हाइड्रोजन पेरोक्साइड का निर्माण करता है। एचओसीएल, गर्म तेल भट्टी ट्यूब सपोर्टिंग हैंगर लिए जीईएम बोलियों को आमंत्रित करता है। हॉट

Hindustan Organic Chemicals Ltd. is a Govt. of India Undertaking manufacturing Phenol, Acetone & Hydrogen Peroxide at its plant at Kochi, Kerala, India. HOCL invites GEM Bids for Hot Oil Furnace Tube Supporting Hangers

You may submit your offer on two bid system online before the due date and time specified.

अर्नेस्ट मनी डिपॉजिट (ईएमडी) EARNEST MONEY DEPOSIT (EMD): Rs.13,950/-

आपका विश्वासी,

हिंदुस्तान ऑर्गेनिक केमिकल्स लिमिटेड के लिए

Thanking you,

Yours faithfully,

For Hindustan Organic Chemicals Ltd.

बी बालचन्द्रन B. BALACHANDRAN

मुख्य महाप्रबंधक (सामग्री/ विपणन/ एच आर/ व्यापार विकास) CGM(Materials/Mktg/HR/BD)

हिंदुस्तान ऑर्गेनिक केमिकल्स लिमिटेड

HINDUSTAN ORGANIC CHEMICALS LIMITED

(भारत सरकार का उद्यम A Govt.of India Enterprise)

अंबलमुगल, कोची, केरल Ambalamugal, Kochi, Kerala-682302

Tel:0484-2727364.

** इस निविदा के हिंदी तथा अंग्रेजी संस्करणों में किसी भी प्रकार की विसंगति होने पर अंग्रेजी संस्करण को मूल एवं प्रभावी माना जाएगा।*

In case of any discrepancy between the Hindi and English versions of this tender, the English version shall be treated as the original and will prevail.

सूची – निविदा दस्तावेज INDEX - TENDER DOCUMENTS

1	बोली में भाग लेने के लिए पात्रता मानदंड Eligibility criteria for participating in the bid	अनुबंध Annexure-I
2	विशेष विवरण / विनिर्देश Specification	अनुबंध Annexure-II
3	निविदा की सामान्य शर्तें एवं नियम General Terms and conditions of the tender	अनुबंध Annexure-III
4	वाणिज्यिक शर्तों का प्रारूप Commercial Term Formats	अनुबंध Annexure-IV- A,B,C
5	बोली सुरक्षा घोषणा Bid Security Declaration	अनुबंध Annexure-V
6	भारत की स्थलीय सीमा साझा करने वाले देशों के विक्रेताओं के अनिवार्य पंजीकरण से संबंधित प्रावधान का अनुपालन (DPIIT के अनुसार) Compliance To Clause W.R.T Mandatory Registration Of Vendors From Countries Sharing Land Border With India, With DPIIT	अनुबंध Annexure-VI

बोली में भाग लेने के लिए पात्रता मानदंड. Eligibility criteria for participating in the bid.**विचार किया जाएगा जो निम्नलिखित पात्रता मानदंडों को पूरा करते हैं।****Offers of bidders who satisfy the following Eligibility Criteria only will be considered .**

- a. विक्रेता ने पिछले तीन वित्तीय वर्षों में समान वस्तुओं के लिए ऑर्डर निष्पादित किया हो
Vendor must have executed orders for similar items in the last three financial years
- b. समान वस्तुओं के लिए कम से कम 3 प्रतिष्ठित ग्राहकों (अधिमानत: सार्वजनिक क्षेत्र के उपक्रमों/सरकारी संगठनों) के कार्य आदेश की प्रतियां अपलोड होनी चाहिए।
Vendor should have upload work order copies of Minimum 3 Nos of ReputedCustomers preferably PSUs/Govt. Organisations for similar items
- c. समान वस्तुओं के लिए प्रतिष्ठित संगठनों (अधिमानत: सार्वजनिक क्षेत्र के उपक्रमों) द्वारा जारी किए गए कार्य आदेश की प्रतियां या संतोषजनक प्रदर्शन प्रमाण पत्र दोहराए जाएं।
Repeat works order copies or satisfactory performance certificates issued by reputed organizations preferably PSUs for similar items
- d. ग्राहक सूची
Client list
- e. तकनीकी मूल्यांकन के लिए पिछले प्रदर्शन पर विचार किया जाएगा
Past performance will be considered for technical evaluation

विक्रेता को तकनीकी बोली के साथ उपरोक्त सभी के लिए दस्तावेजी साक्ष्य प्रस्तुत करने होंगे। उक्त श्रेणी के लिए एचओसीएल पंजीकृत विक्रेताओं को बिंदु संख्या ' बी ' से ' ई ' तक उपरोक्त दस्तावेज प्रस्तुत करने से छूट दी गई है।

Vendor should provide documentary evidences for all the above along with the Technical Bid. HOCL registered vendors for the said category are exempted from furnishing above document as in point nos a to d.

विनिर्देशन प्रपत्र SPECIFICATION SHEET

आइटम नंबर Item Number	आइटम विवरण Item Description	वस्तु की मात्रा Item Quantity	माप की इकाई Unit of Measure
1	RADIANT SECTION WALL TUBE HANGER AS PER DRG NO. 7-17-0118 REV.7. MANUFACTURING STANDARD, DIMENSIONAL TOLERANCES, QUALITY CONTROL, INSPECTION, TESTING & GUARANTEE ETC. SHALL COMPLY AS PER EIL SPEC NO. 6-17-0007 REV.5 MOC : A351 GR. HK40 (25Cr - 20Ni)	136	NOS.
2	ARCH SECTION TUBE HANGER AS PER DRG NO. HOC/MECH/F6001/TUBE HANGER/ARCH SEC. MANUFACTURING STANDARD, DIMENSIONAL TOLERANCES, QUALITY CONTROL, INSPECTION, TESTING & GUARANTEE ETC. SHALL COMPLY AS PER EIL SPEC NO. 6-17-0007 REV.5 MOC : A351 GR. HK40 (25Cr - 20Ni)	4	NOS.
3	CONVECTION SECTION TUBE HANGER AS PER DRG NO. HOC/MECH/F6001/TUBE HANGER/CONVECTION SEC. MANUFACTURING STANDARD, DIMENSIONAL TOLERANCES, QUALITY CONTROL, INSPECTION, TESTING & GUARANTEE ETC. SHALL COMPLY AS PER EIL SPEC NO. 6-17-0007 REV.5 MOC : A351 GR. HK40 (25Cr - 20Ni)	4	NOS.
4	HINGE PIN FOR ARCH & CONVECTION SECTION TUBE HANGER AS PER DRG NO. HOC/MECH/F6001/HINGE PIN FOR TUBE HANGER MANUFACTURING STANDARD, DIMENSIONAL TOLERANCES, QUALITY CONTROL, INSPECTION, TESTING & GUARANTEE ETC. SHALL COMPLY AS PER EIL SPEC NO. 6-17-0007 REV.5 MOC : A351 GR. HK40 (25Cr - 20Ni)	8	NOS.
5	SUPPORTING PLATE FOR CONVECTION SECTION TUBE HANGER AS PER DRG NO. HOC/MECH/F6001/SUPPORTING PLATE FOR TUBE HANGER MANUFACTURING STANDARD, DIMENSIONAL TOLERANCES, QUALITY CONTROL, INSPECTION, TESTING & GUARANTEE ETC. SHALL COMPLY AS PER EIL SPEC NO. 6-17-0007 REV.5 MOC : A351 GR. HK40 (25Cr - 20Ni)	4	Nos

NOTE:

- **ACCEPATBLE DELIVERY PERIOD IS 2-3 MONTHS FROM THE DATE OF PLACEMENT OF PURCHASE ORDER.**
- **DRAWING AND QAP SHALL BE SUBMITTED FOR APPROVAL PRIOR TO COMMENCEMENT OF MANUFACTURING. THE QAP SHALL BE PREPARED IN ACCORDANCE WITH EIL SPEC NO. 6-17-0007 REV.5 (ATTACHED).**
- **ALL CERTIFICATES, INCLUDING RADIOGRAPHY (LEVEL 2), CHEMICAL AND MECHANICAL TEST CERTIFICATES, ETC., AS PER EIL SPEC NO. 6-17-0007 REV. 5, SHALL BE SUBMITTED ALONG WITH THE SUPPLY.**
- **THIRD PARTY INSPECTION : PLEASE NOTE THAT THIRD PARTY INSPECTION WILL BE APPLICABLE IN THIS PROCUREMENT. YOU SHALL INTIMATE US WHEN THE ITEMS ARE READY. WE WILL ARRANGE FOR THIRD PARTY INSPECTION (TPI) OF MATERIALS THROUGH OUR APPROVED TPI AGENCY.**
- **MATERIALS WILL HAVE TO BE INSPECTED AT THE VENDOR'S WORKS PRIOR TO DESPATCH AND SHALL BE DESPATCHED ONLY AFTER THE INSPECTION & APPROVAL BY THE TPI. THE INSPECTION WITNESSING CHARGES TO THE THIRD PARTY SHALL BE BORNE BY HOCL AS PER HOCL'S AGREEMENT WITH THE THIRD PARTY. HOWEVER WHATEVER COST INCURRING FOR INSPECTION OF MATERIAL (LIKE NDT ETC.) SHOULD BE BORNE BY THE SUPPLIER. HENCE AS PER THE GEM TENDER TERMS THE RATE QUOTED SHALL BE ALL INCLUSIVE. INSPECTION OF THE MATERIAL WILL BE CONDUCTED ON A MUTUALLY AGREED DATE AFTER THE COMPLETION OF MANUFACTURING AND NECESSARY TESTING. ANY DEVIATIONS OR NON-CONFORMITIES IDENTIFIED DURING THE INSPECTION MUST BE CORRECTED BY THE VENDOR. A RE-INSPECTION WILL BE CONDUCTED ON A MUTUALLY AGREED DATE TO VERIFY THE CORRECTIONS. COST OF THE RE-INSPECTION INCURRED TO HOCL AS THIRD PARTY INSPECTION COST SHALL BE BORNE BY THE VENDOR. PLEASE NOTE THAT THE ITEM WILL BE FINAL ACCEPTED ONLY AFTER INSPECTION AND APPROVAL BY OUR DESIGNATED ENGINEER AT THE HOCL SITE.**
- **DRAWINGS ATTACHED.**
- **THESE ITEMS ARE REQUIRED FOR ANNUAL SHUTDOWN WORKS. HENCE THE SUPPLIER SHOULD STRICTLY ADHERE TO THE DELIVERY PERIOD. ALL THE PROCESSES LIKE DRAWING APPROVAL, THIRD PARTY INSPECTION AND DISPATCHING OF THE MATERIAL ETC SHOULD BE COMPLETED WITHIN THE OFFERED DELIVERY PERIOD.**

ई-बोली प्रस्तुत करने के लिए सामान्य नियम और शर्तें
GENERAL TERMS AND CONDITIONS FOR E BID SUBMISSION

कृपया नीचे दिए गए निर्देशों के अनुसार संलग्न विनिर्देशों और नियमों व शर्तों के अनुरूप अपनी ई-बोली प्रस्तुत करें :-

Please submit your e-bids conforming to the specifications and the terms and conditions attached as per instructions given below:-

1. बोली में निम्नलिखित अनुपालन कथन को इसके अभिन्न अंग के रूप में शामिल किया जाएगा: "हमने इस जांच का हिस्सा बनने वाले खरीद और संबंधित दस्तावेजों की शर्तों और नियमों को पढ़, समझ और स्वीकार कर लिया है और इसके अनुपालन में माल की आपूर्ति करने के लिए सहमत हैं।"

The bid shall contain as integral part of the same the following compliance statement: "We have read, understood and accepted the terms and conditions of purchase and related documents forming part of this enquiry and agree to supply the goods in compliance with the same."

2. बोलीदाताओं को इस पूछताछ के दस्तावेजों का ध्यानपूर्वक अध्ययन करना चाहिए। पूछताछ में उल्लिखित सभी नियम व शर्तें बोलीदाताओं पर बाध्यकारी होंगी, जब तक कि वे किसी भी बोली को स्वीकार करते समय HOCL द्वारा स्पष्ट रूप से बताई गई किसी भी नियम व शर्त के विपरीत न हों।

Bidders should carefully study the documents of this enquiry. All terms and conditions set out there in the enquiry shall be binding on the bidders unless conflicting with any terms and conditions expressly stated by HOCL while accepting any bid, in the event of such acceptance.

3. बोलियां प्राप्त और खोलने की नियत तारीख से न्यूनतम 60 दिनों के लिए वैध होंगी।

Bids shall be valid for a minimum of 60 days from the due date for receipt and opening of the bids.

4. उत्पाद का विनिर्देश: प्रस्तावित उत्पाद का विनिर्देश तकनीकी बोली के साथ अपलोड किया जाएगा।

Specification of the Product: Specifications offered product shall be uploaded along with technical bid.

5. **अर्नेस्ट मनी डिपॉजिट (ईएमडी):** बोली के साथ तकनीकी बोली के साथ 13,950/- रुपये की वापसी योग्य ईएमडी भी होगी। ईएमडी किसी भी राष्ट्रीयकृत/अनुसूचित बैंक से बीमा सुरक्षा बांड/एनईएफटी/आरटीजीएस/बैंक गारंटी के रूप में प्रस्तुत किया जा सकता है। एनईएफटी/आरटीजीएस हमारे बैंकर मेसर्स स्टेट बैंक ऑफ इंडिया, शाखा : सीबीडी बेलापुर, खाता संख्या : 00000037881840330, आईएफएससी: एसबीआई0013551 के माध्यम से हिंदुस्तान ऑर्गेनिक केमिकल्स लिमिटेड को प्रेषित किया जा सकता है।आपके प्रस्ताव में बैंक हस्तांतरण का विवरण इंगित किया जाना चाहिए। सफल निविदा का ईएमडी देय पीबीजी के खिलाफ समायोजित किया जा सकता है। निविदाकर्ता का ईएमडी जब्त कर लिया जाएगा यदि वह निविदा की वैधता अवधि के भीतर किसी भी संबंध में अपनी निविदा वापस लेता है या उसमें संशोधन करता है या निविदा को खराब करता है या उससे कम करता है

एचओसीएल विक्रेताओं, पीएसयू और एमएसई के साथ पंजीकृत विक्रेताओं को पहले से ही सामग्री की आपूर्ति की है, ईएमडी जमा करने की आवश्यकता नहीं है। एमएसई विक्रेताओं को तकनीकी-वाणिज्यिक बोली के साथ वैध एनएसआईसी पंजीकरण/यूएएम/छूट प्रमाण पत्र जमा करना होगा। एमएसई श्रेणी के

तहत, केवल वस्तुओं के लिए निर्माता ईएमडी से छूट के लिए पात्र हैं। व्यापारियों को इसके दायरे से बाहर रखा गया है।

EARNEST MONEY DEPOSIT (EMD): Bid shall be accompanied with a refundable EMD of **Rs.13,950/-** along with the technical bid. EMD may be submitted in the form of Insurance security bond /NEFT / RTGS/ Bank Guarantee from any Nationalized/ Scheduled bank. NEFT/ RTGS may remit to Hindustan Organic Chemicals Ltd., through our banker M/s. State bank of India, Branch : CBD BELAPUR, A/c. No. 00000037881840330, IFSC: SBIN0013551. Details of bank transfer should be indicated in your offer. EMD of the successful tender may be adjusted against the PBG payable. EMD of a tenderer shall be forfeited if he withdraws or amends his tender or impairs or derogates from the tender in any respect within the validity period of the tender.

HOCL Vendors who have already supplied the material to HOCL, PSUs and Vendors registered with MSE need not submit EMD. MSE vendors have to submit valid NSIC registration/UAM/exemption certificate along with the Techno-commercial bid. Under MSE category, only manufacturers for goods are eligible for exemption from EMD. Traders are excluded from the purview of this.

6. भुगतान शर्तें होंगी: एचओसीएल मानक भुगतान अवधि एचओसीएल अम्बलमुगल में हमारी साइट पर सामग्री की प्राप्ति और स्वीकृति की तारीख से 30 दिनों के भीतर है।
Payment terms shall be: HOCL Standard Payment Term is Within 30 days from the date of Receipt & Acceptance of Material at our Site at HOCL Ambalamugal.
7. यदि एचओसीएल चाहे, तो निविदाकर्ता को अपने कार्यस्थल पर सामग्री के निरीक्षण के लिए सहमत होना होगा। यह निरीक्षण एचओसीएल के प्रतिनिधि, किसी तृतीय पक्ष या संयुक्त रूप से किया जा सकता है।
Tenderer should agree for inspection of material at their site, if desired by HOCL. The inspection may be carried out by the representative of HOCL or by a third party or jointly.
8. निविदाकर्ता को बोली में प्रस्तुत सामग्री का जीएसटीआईएन नंबर एवं एचएसएन कोड अवश्य बताना होगा।
The Tenderer must specify their GSTIN No& HSN code of material offered in the BID.
9. सफल निविदाकर्ता, यदि एचओसीएल चाहे, तो आदेश के संतोषजनक निष्पादन हेतु आदेश के 21 दिनों के भीतर आदेश मूल्य के 5% के बराबर राशि सुरक्षा जमा के रूप में जमा करेगा। एचओसीएल द्वारा इस राशि पर कोई ब्याज नहीं दिया जाएगा। यदि लागू हो, तो पक्षकार के लिखित अनुरोध पर 60 दिनों के भीतर सुरक्षा जमा राशि वापस कर दी जाएगी।
The successful tenderer shall, if so desired by HOCL, deposit an amount equivalent to 5% of the value of order as security deposit within 21 days of the order towards satisfactory execution of the order. No interest will be paid on this amount by HOCL.SD ,if applicable, will be refunded within 60 days against written request from party.
10. पीओ के प्लेसमेंट की तारीख से 2-3 महीनों के भीतर डिलीवरी। डिलीवरी शेड्यूल एचओसीएल द्वारा दिया जाएगा और आप शेड्यूल के अनुसार आपूर्ति की व्यवस्था करने के लिए जिम्मेदार होंगे। यदि आपूर्तिकर्ता निर्धारित अवधि के भीतर कंसाइनमेंट वितरित करने में विफल रहता है, तो एचओसीएल को, यदि एचओसीएल द्वारा वांछित है, आपूर्तिकर्ता के लंबित बिलों से आदेश के खिलाफ या किसी अन्य बिलों से एचओसी के विवेक पर प्रति सप्ताह बकाया माल की कीमत का 0.5% जुर्माना वसूलने का अधिकार होगा, जो अधिकतम 5% तक होगा।
Delivery within 2-3 months from the date of placement of PO. The delivery schedule shall be given by HOCL and you shall be responsible for arranging supplies as per the schedule. In case the supplier fails to deliver the consignment within the period prescribed, HOCL shall be entitled, if so desired by HOCL, to recover from supplier's

pending bills against the order or from any other bills a penalty of 0.5% of the price of the goods in arrears per week at discretion of the HOC subject to maximum of 5%.

11. आपूर्ति के साथ निर्माता का मूल या सत्यापित परीक्षण प्रमाणपत्र, मूल गारंटी प्रमाणपत्र, मूल चित्र आदि, जैसा भी लागू हो, प्रदान किया जाएगा।
Manufacturers test certificate in original or attested, guarantee certificates in original, drawings in original etc. as applicable shall be provided along with the supply.
12. निविदाकर्ता, जहाँ भी आवश्यक हो, आवश्यक कैटलॉग/ड्राइंग/वस्तुओं के विस्तृत विवरण संलग्न कर सकता है। साथ ही, प्रस्तावित वस्तु का मेक/मॉडल भी स्पष्ट रूप से निर्दिष्ट करें।
Tenderer may attach necessary catalogues/drawings/detailed specifications of the items wherever required. Also clearly specify the make/model of the item offered.
13. सार्वजनिक क्षेत्र के उपक्रमों/लघु उद्योग इकाइयों आदि के लिए क्रय प्राथमिकताएँ, बयाना राशि/स्थायी जमा छूट आदि भारत सरकार के समय-समय पर जारी निर्देशों के अनुसार लागू होंगी। इसके लिए, निविदाकर्ता को अपने प्रस्ताव में ही सहायक दस्तावेजों के साथ अपनी पात्रता का दावा करना होगा।
Purchase preferences, EMD/SD Exemption etc for PSUs/SSI units etc will be applicable as per GOI directives from time to time. For this, the tenderer should claim their eligibility along with the supporting documents in their offer itself.
14. बोली को अस्वीकार करने का अधिकार : एचओसीएल किसी भी बोली को निम्नलिखित कारणों से अस्वीकार करने का अधिकार सुरक्षित रखता है: (क) विक्रेता द्वारा उपरोक्त बोली प्रक्रिया का पालन न करना (ख) विक्रेता का एचओसीएल को तकनीकी रूप से स्वीकार्य न होना (ग) तकनीकी वाणिज्यिक बोली के साथ ईएमडी भुगतान विवरण प्रस्तुत न करना या निर्धारित राशि से कम ईएमडी का भुगतान करना (घ) विक्रेता का निविदा की सामान्य शर्तों से सहमत न होना। (ङ) मांगे गए किसी विशेष दस्तावेज को संलग्न न करना (च) कोई अन्य वैध कारण।
RIGHT TO REJECT A BID: HOCL reserves the right to reject any bid due to reasons such as (a) Vendor not following above bidding procedures (b) Vendor not being technically acceptable to HOCL (c) Non submission of EMD payment details with the techno commercial bid or EMD paid being lesser than the stipulated amount (d) Vendor not agreeing with the general conditions of the tender. (e) Not enclosing any particular documents asked for (f) Any other valid reasons.
15. मूल्य: उद्धृत मूल्य अम्बालामुगल , एर्नाकुलम जिला, केरल राज्य स्थित हमारे कारखाने में डिलीवरी के लिए होगा। विक्रेता द्वारा उद्धृत मूल्य अनुबंध अवधि के दौरान स्थिर रहेगा।
PRICE: The price quoted shall be for delivery at our factory at Ambalamugal, Ernakulam District, Kerala state. The price quoted by the vendor shall remain firm during the period of contract.
16. भारत के साथ भूमि सीमा साझा करने वाले बोलीदाता से खरीद पर प्रतिबंध
1. भारत के साथ भूमि सीमा साझा करने वाले किसी भी देश का बोलीदाता बोली लगाने के लिए तभी पात्र होगा जब वह उद्योग एवं आंतरिक व्यापार संवर्धन विभाग (DPIIT) में पंजीकृत हो। (कृपया कार्यालय जापन संख्या 6/18/2019-PPD दिनांक 23 जुलाई 2020 देखें) ऐसे बोलीदाताओं को निविदा के साथ पंजीकरण प्रमाणपत्र की वैध प्रति प्रस्तुत करनी होगी। हालाँकि, पंजीकरण की उक्त आवश्यकता उन देशों के बोलीदाताओं पर लागू नहीं होगी जिन्हें भारत सरकार ने ऋण दिया है या जिनमें भारत सरकार परियोजनाओं के विकास में लगी हुई है। बोलीदाता विदेश मंत्रालय की वेबसाइट पर उपलब्ध ऐसे देशों की अद्यतन सूची से स्वयं को अवगत करा सकते हैं।

2. सभी बोलीदाताओं को बोली के साथ अनुलग्नक VI में दिए गए प्रारूप के अनुसार उपरोक्त खंड के संबंध में अनुपालन प्रमाण पत्र प्रस्तुत करना होगा।

Restriction on procurement from Bidder who shares the land border with India

- Any bidder from a country which shares a land border with India will be eligible to bid, only if the bidder is registered with the Department for promotion of Industry and Internal Trade (DPIIT). (Pl. refer office Memorandum no. 6/18/2019-PPD dated 23rd July 2020) Such bidders should submit the valid copy of registration certificate along with tender. However the said requirement of registration will not be applicable to bidders from those country to which Govt. of India has extended lines of credit or in which Govt. of India is engaged in development of projects. Bidders may appraise themselves of the updated lists of such countries available in the website of Ministry of External Affairs.
- All Bidders shall furnish compliance certificate with respect to above clause as per the format in Annexure VI along with the bid

17. विवादों का मध्यस्थता :-

इस निविदा/समझौते/क्रय आदेश/कार्य आदेश से उत्पन्न, इसके अंतर्गत या इससे संबंधित सभी विवादों, मतभेदों, प्रश्नों और दावों का पक्षों के बीच आपसी चर्चा के माध्यम से सौहार्दपूर्ण ढंग से निपटारा किया जाएगा। यदि पक्ष 21 दिनों के भीतर आपसी परामर्श से विवाद को सुलझाने में विफल रहते हैं, तो ऐसे विवाद, मतभेद, प्रश्न या दावे किसी भी पक्ष द्वारा मध्यस्थता के माध्यम से समाधान के लिए भारत अंतर्राष्ट्रीय मध्यस्थता केंद्र या मध्यस्थों के पैनल में से पक्षों द्वारा परस्पर सहमत एकमात्र मध्यस्थ के पास भेजे जाएंगे। मध्यस्थता का पुरस्कार अंतिम होगा और पक्षों पर बाध्यकारी होगा। मध्यस्थता का स्थान कोच्चि, केरल, भारत में होगा और मध्यस्थता की कार्यवाही भारत अंतर्राष्ट्रीय मध्यस्थता केंद्र अधिनियम 2019 / भारतीय मध्यस्थता और सुलह अधिनियम 1996 या वर्तमान में लागू किसी वैधानिक संशोधन या पुनः अधिनियमन के अनुसार कोच्चि, केरल, भारत में आयोजित की जाएगी।

जब अनुबंध विदेशी विक्रेता के साथ होता है, तो विक्रेता के पास भारत अंतर्राष्ट्रीय मध्यस्थता केंद्र अधिनियम 2019 / भारतीय मध्यस्थता और सुलह अधिनियम, 1996 / UNCITRAL (अंतर्राष्ट्रीय व्यापार कानून मध्यस्थता पर संयुक्त राष्ट्र आयोग) मध्यस्थता नियमों के प्रावधानों के अनुसार मध्यस्थता चुनने का विकल्प होता है।

ARBITRATION OF DISPUTES:-

All disputes, differences, questions and claims arising out of, under or touching upon this Tender /Agreement/ Purchase Order/ Work Order shall be settled amicably between the parties through mutual discussion. If the parties fail to resolve the dispute by such mutual consultation within 21 days, then such disputes, difference, questions or claims shall be referred for resolution through arbitration by either of the parties to the India International Arbitration Centre or a Sole Arbitrator mutually agreed upon by the parties from a panel of arbitrators. The award of Arbitration shall be final and binding on the parties. The seat of the Arbitration shall be at Kochi, Kerala, India and the proceedings of the arbitration shall be held at Kochi, Kerala, India in accordance with the India International Arbitration Centre Act 2019 / Indian Arbitration & Conciliation Act 1996 or any statutory modification or re-enactment thereof for the time being in force.

When the contract is with foreign vendor, the vendor has the option to choose arbitration in accordance with the provisions of The India International Arbitration Centre Act 2019 / The Indian Arbitration and Conciliation Act, 1996 / UNCITRAL (United Nations Commission on International Trade Law Arbitration) Arbitration Rules."

18. क्षेत्राधिकार :- इस अनुबंध के अंतर्गत या इसके संबंध में उत्पन्न होने वाले सभी प्रश्न, विवाद या मतभेद केवल एर्नाकुलम, केरल, भारत के न्यायालयों के अनन्य क्षेत्राधिकार के अधीन होंगे।

JURISDICTION:- All questions, disputes or differences arising under or in connection with this contract shall be subject to the exclusive jurisdiction of the courts in Ernakulam, Kerala, India only.

19. **बोली के सभी पृष्ठों पर हस्ताक्षर और मुहर लगाना :-** विक्रेता को प्रस्तुत बोलियों के सभी पृष्ठों को विधिवत भरना होगा, हस्ताक्षर करना होगा और मुहर लगानी होगी, अन्यथा बोलियां अस्वीकृत कर दी जाएंगी।

SIGNING AND SEALING ON ALL PAGES OF BID :- The vendor shall duly fill, sign and seal on all the pages of the bids submitted failing which bids are liable to be rejected.

20. **एमएसएमई व्यवसाय के विकास में सहायता के लिए सामान्य जानकारी :-**

भारत सरकार एमएसएमई व्यवसायों की गुणवत्ता और स्थिरता को बढ़ाने के लिए दो उत्कृष्ट अवसर प्रदान करती है - जेडईडी प्रमाणन (शून्य दोष शून्य प्रभाव) और एमएसएमई प्रतिस्पर्धी (लीन) योजना - दोनों को उत्पाद की गुणवत्ता में सुधार, प्रतिस्पर्धात्मकता बढ़ाने और सरकारी लाभों तक पहुंच प्रदान करने के लिए डिज़ाइन किया गया है।

पात्र एमएसएमई ऑनलाइन पोर्टल: <https://zed.msme.gov.in/> के माध्यम से आवेदन कर सकते हैं।
<https://lean.msme.gov.in/> .

GENERAL INFORMATION TO SUPPORT THE GROWTH OF MSME BUSINESS:-

" The Government of India offers two excellent opportunities to elevate the quality and sustainability of MSME businesses—the ZED Certification (Zero Defect Zero Effect) and the MSME Competitive (Lean) Scheme—both designed to improve product quality, enhance competitiveness, and provide access to government benefits."

Eligible MSMEs shall apply through online portal: <https://zed.msme.gov.in/>
<https://lean.msme.gov.in/>.

वाणिज्यिक शब्द प्रारूप COMMERCIAL TERM FORMAT

(कृपया नीचे दिए गए विवरण को अपने लेटर हेड में भरें और अपनी बोली के साथ अपलोड करें)
(Please fill up the details mentioned below in your letter head and upload along with your bid)

जेम पोर्टल के माध्यम से ऑफर के लिए (केवल जेम मानक नियम और शर्तों के अनुसार, कोई विचलन की अनुमति नहीं होगी)

For offers through GEM portal (as per GEM standard terms and conditions only, no deviation will be allowed)

भुगतान की अवधि एचओसीएल अम्बलमुगल में हमारी साइट पर सामग्री की प्राप्ति और स्वीकृति की तारीख से 30 दिनों के भीतर है। Payment term is within 30 days from the date of receipt & acceptance of material at our site at HOCL Ambalamugal.

उद्धृत दर में जीएसटी और साइट पर सामग्री पहुंचाने का भाड़ा शुल्क शामिल होना चाहिए
Rate quoted should be inclusive of gst and freight charges to deliver the material at site

क्रम संख्या SI.No	आवश्यक विवरण DETAILS REQUIRED	
1	संगठन का नाम और पता Name and Address of Organization	
2	फोन नंबर Phone No	
3	जीएसटीआईएन GSTIN	
4	पत्राचार के लिए ई-मेल आईडी E-mail id for correspondence	
5	संपर्क व्यक्ति का नाम और मोबाइल नंबर Contact Person Name and Mobile No	
6	क्या एमएसएमई/एनएसआईसी के साथ पंजीकृत हैं (यदि हां तो कृपया दस्तावेजी प्रमाण संलग्न करें): Whether registered with MSME/NSIC (If so pl. enclose documentary proof):	
7	क्या प्रस्तावित वस्तु का निर्माता Whether manufacturer of offered item	<input type="radio"/> हाँ Yes <input type="radio"/> नहीं No
8	ऑफर की वैधता Validity of offer	
9	वितरण अवधि Delivery period	
10	आपूर्ति के साथ प्रदान किए गए प्रमाण पत्र, यदि कोई हो Certificates provided along with supply, if any	<input type="radio"/> हाँ Yes <input type="radio"/> नहीं No
11	विनिर्देश में विचलन , यदि कोई हो Deviation in specification ,if any	
<p>मैं/हम यहां पुष्टि करते हैं कि मुझे/हमें अतीत में किसी भी सार्वजनिक क्षेत्र के उपक्रम/सरकारी संगठन द्वारा काली सूची में नहीं डाला गया है। I/We here by confirm that, I/We have not been blacklisted in the past by any Public Sector Undertakings/ Government organizations.</p>		
<p>हस्ताक्षर और मुहर Signature and Stamp</p>		

अनुबंध IV – बी ANNEXURE IV – B

(कृपया इस शीट को भरें और वाणिज्यिक/तकनीकी बोली में जमा करें)
(KINDLY FILL THIS SHEET AND SUBMIT IN -COMMERCIAL/TECHNICAL BID)

बोलीदाता का नाम Name of Bidder:		
क्रम संख्या Sl. No.	वाणिज्यिक खंड Commercial Clauses	बोलीदाता की पुष्टि (कृपया अपनी पुष्टि के आगे √ लगायें) Bidder Confirmation (Please put √ in front of your confirmation)
1	क्या बोलीदाता (स्वामित्व संस्था, साझेदारी फर्म, कंपनी) वर्तमान में अवकाश सूची/काली सूची/डी-लिस्टेड में है या किसी सार्वजनिक क्षेत्र के उपक्रम/सरकारी संगठन में अवकाश सूची/काली सूची/डी-लिस्टेड में रखा गया है। यदि हाँ, तो विवरण दें। Whether bidder (a proprietary concern, Partnership Firm, Company) is currently on holiday list/black list/de-listed or has been put on holiday/blacklisted/de-listed at any PSU/govt. Organization. If so, give details.	<input type="checkbox"/> हाँ, हम अवकाश सूची/काली सूची/डी-सूची में हैं <input type="checkbox"/> नहीं Yes, We are on holiday List/Black List/De-List
2i	क्या पार्टी सूक्ष्म/लघु/मध्यम उद्यम अधिनियम 2006 के अंतर्गत पंजीकृत है (कृपया प्रमाण प्रस्तुत करें) Whether the party is registered under Micro/Small/Medium Enterprises act 2006 (Please furnish the proof)	<input type="checkbox"/> सूक्ष्म Micro <input type="checkbox"/> मध्यम Medium <input type="checkbox"/> छोटा Small <input type="checkbox"/> नहीं No
2-ii	एमएसई बोलीदाता की स्थिति Status of MSE Bidder	<input type="checkbox"/> निर्माता Manufacturer <input type="checkbox"/> सेवाएँ Services <input type="checkbox"/> लागू नहीं Not Applicable
2-iii	क्या एमएसई बोलीदाता स्वयं द्वारा निर्मित उत्पाद की पेशकश कर रहा है? Whether MSE bidder is offering product manufactured by him/her	<input type="checkbox"/> हाँ Yes <input type="checkbox"/> नहीं No
3i	सभी एमएसई बोलीदाताओं को सीपीपी पोर्टल पर अपना यूएम नंबर पंजीकृत/घोषित करना होगा और इस पंजीकरण/घोषणा की प्रति प्रस्ताव के साथ संलग्न करनी होगी; ऐसा न करने पर ऐसे बोलीदाता एमएसएमई आदेश, 2012 के लिए पीपी नीति के अनुसार लाभ नहीं उठा पाएंगे। <u>एसएसआई/एमएसएमई/एनएसआईसी/यूएम/डीआईसी पंजीकरण प्रमाणपत्र</u> All MSE bidders shall register / declare their UAM Number on CPP Portal and copy of this registration / declaration shall be attached with the offer; failing which such bidders will not be able to enjoy benefits as per PP Policy for MSME order, 2012. <u>SSI/MSME/NSIC/UAM /DIC registration</u>	<input type="checkbox"/> यू ए एम नंबर का उल्लेख करें Mention UAM Number <input type="checkbox"/> लागू नहीं Not Applicable
3-ii	खंड संख्या 3i के विरुद्ध वैध दस्तावेज़ प्रस्तुत किया गया Submitted valid document against clause no 3i	<input type="checkbox"/> प्रस्तुत Submitted <input type="checkbox"/> लागू नहीं Not Applicable

4i	क्या "एमएसएमई" उद्यम का स्वामी एससी/ एसटी वर्ग से है (कृपया सक्षम प्राधिकारी द्वारा जारी जाति प्रमाण पत्र संलग्न करें)Whether the proprietor of "MSME" enterprise is from SC/ST category (Please attach caste certificate issued by competent authority)	<input type="checkbox"/> हाँ Yes <input type="checkbox"/> नहीं No
4ii	क्या "एमएसएमई" उद्यम की मालिक महिला है (अर्थात महिला स्वामित्व, या साझेदारी/निजी लिमिटेड कंपनियों के मामले में न्यूनतम 51% शेयर धारक) Whether the proprietor of "MSME" enterprise is woman (i.e. Woman proprietorship, or holding minimum 51% shares in case of Partnership/Private Limited Companies)	<input type="checkbox"/> हाँ Yes <input type="checkbox"/> नहीं No
4iii	खंड संख्या 4ii के विरुद्ध प्रस्तुत प्रमाण पत्र Submitted certificate against clause no 4ii	<input type="checkbox"/> प्रस्तुत Submitted <input type="checkbox"/> लागू नहीं Not
5	<p>पूछताछ के सभी नियमों और शर्तों से सहमत: इसके द्वारा यह कहा जाता है कि प्रस्तुत उद्धरण/प्रस्ताव जांच के विरुद्ध जारी किए गए दस्तावेजों के पूर्ण अनुपालन में है और यह भी पुष्टि की जाती है कि जांच के अनुसार सभी नियमों और शर्तों से कोई विचलन नहीं है । जांच दस्तावेजों में उल्लिखित एचओसीएल के मानक नियमों और शर्तों को अस्वीकार करने या उनसे विचलन करने पर प्रस्ताव को अस्वीकार किया जा सकता है, स्पष्टीकरण के लिए कोई पत्राचार नहीं किया जाएगा। AGREED TO ALL TERMS AND CONDITIONS OF ENQUIRY: It is hereby stated that the quotation/offer submitted is in full compliance with the documents issued against the enquiry and also further confirmed that there is no deviation from all the terms and conditions as per the enquiry.Non-acceptance or deviation to HOCL's standard terms and conditions mentioned in enquiry documents may lead to rejection of offer, no correspondence shall be done for clarifications</p>	<input type="checkbox"/> सहमत Agreed <input type="checkbox"/> सहमत नहीं Not Agreed
<p>दिनांक DATE : बोलीदाता के हस्ताक्षर और मुहर SIGN AND STAMP OF BIDDER</p>		

अनुबंध V-सी ANNEXURE IV-C**वाणिज्यिक शब्द प्रारूप-सी COMMERCIAL TERM FORMAT-C**

निविदा संख्या _____ के विरुद्ध बोली के साथ प्रस्तुत किया जाने वाला अनुबंध
Annexure to be submitted along with the bid against Tender No. _____
(कृपया वाणिज्यिक/तकनीकी बोली के साथ भरें और जमा करें)
(KINDLY FILL AND SUBMIT ALONG WITH COMMERCIAL/TECHNICAL BID)

बोलीदाता	का	नाम:	NAME	OF	BIDDER:
क्रमांक Sr.No.	वाणिज्यिक खंड	COMMERCIAL CLAUSES	बोलीदाता की पुष्टि (कृपया ✓ लगाएं) BIDDER CONFIRMATION (PLEASE PUT ✓)		
1	कृपया बताएं कि क्या आप क्लास-I/क्लास-II के स्थानीय आपूर्तिकर्ता हैं। (कृपया नीचे दी गई परिभाषा देखें) Please mention whether you are a Class-I/Class II Local supplier.(Please see the definition given below)	कक्षा I Class I			
2	स्थानीय सामग्री का प्रतिशत (%) निर्दिष्ट करें. Specify the percentage (%) of local content.	_____ %			
3	उस स्थान का विवरण जहां स्थानीय मूल्य संवर्धन किया गया है। Details of location at which the local value addition is made.				
4	उल्लेख करें कि क्या प्रस्तुत उत्पाद किसी विदेशी निर्माता से लाइसेंस के तहत भारत में निर्मित है, जिसके पास बौद्धिक संपदा अधिकार हैं और क्या कोई प्रौद्योगिकी सहयोग समझौता / प्रौद्योगिकी हस्तांतरण समझौता है। Mention whether the product offered is manufactured in India under a license from a foreign manufacturer who hold intellectual property rights and there is a technology collaboration agreement / Transfer of technology agreement	हां Yes / नहीं No			

स्थानीय सामग्री की स्व-घोषणा SELF DECLARATION OF LOCAL CONTENT

हम एतद्वारा घोषणा करते हैं कि क्रम संख्या 2 के सामने उल्लिखित स्थानीय सामग्री का प्रतिशत (%) _____% है। हम यह भी समझते हैं कि गलत स्व-घोषणाएँ और ऑडिटर प्रस्तुत करना सामान्य वित्तीय नियमों के नियम 175(1)(i)(h) के अंतर्गत सत्यनिष्ठा संहिता का उल्लंघन होगा, जिसके लिए बोलीदाता या उसके उत्तराधिकारियों को सामान्य वित्तीय नियमों के नियम 151(iii) के अनुसार दो वर्ष तक के लिए प्रतिबंधित किया जा सकता है। साथ ही, कानून के अंतर्गत अनुमत अन्य कार्रवाइयाँ भी की जा सकती हैं।
We hereby declare that the percentage (%) of local content specified against mentioned against Sr.No.2 is _____%. We also understand that submitting False self-declarations and auditors will be in breach of Code of Integrity under Rule 175(1)(i)(h) of the General Financial Rules for which a Bidder or its successors can be debarred for up to Two Years as per the Rule 151 (iii) of the General. Financial Rules along with such other actions as may be permissible under Law.

परिभाषाएं Definitions

स्थानीय सामग्री: - भारत में जोड़े गए मूल्य की मात्रा (खरीदी गई वस्तु का कुल मूल्य घटा वस्तु में आयातित सामग्री का मूल्य (सभी सीमा शुल्क सहित) कुल मूल्य के अनुपात के रूप में, प्रतिशत में)।

Local Content: - The amount of value added in India (Total value of item procured minus the value of imported content in the item (including all customs duties) as a proportion of total value, in percentage.

वर्ग I स्थानीय आपूर्तिकर्ता: - आपूर्तिकर्ता या सेवा प्रदाता जिसके क्रय हेतु प्रस्तुत माल, सेवा या कार्य में स्थानीय सामग्री 50% के बराबर या उससे अधिक है।

Class I Local Supplier: - Supplier or service provider whose goods, services or works offered for procurement has local content equal to or more than 50%.

वर्ग II स्थानीय आपूर्तिकर्ता: - आपूर्तिकर्ता या सेवा प्रदाता जिसके क्रय हेतु प्रस्तुत माल, सेवा या कार्य में स्थानीय सामग्री 20% से अधिक किन्तु 50% से कम है।

Class II Local Supplier: - Supplier or service provider whose goods, services or works offered for procurement has local content more than 20% but less than 50 %.

क्रय वरीयता: - लागू सरकारी आदेश के अनुसार होगी।

Purchase Preference: - Will be as per the applicable Government order.

तारीख

DATE

हस्ताक्षर और मुहर

SIGNATURE AND STAMP

बोली सुरक्षा घोषणा
BID SECURITY DECLARATION

निविदा संख्या _____ के विरुद्ध बोली के साथ प्रस्तुत किया जाने वाला अनुलग्नक

ANNEXURE TO BE SUBMITTED ALONG WITH THE BID AGAINST TENDER NO _____

मैं/हम

.....एतद्वारा

घोषणा करता/करती हूँ कि:

I/We.....hereby declare that:

1. मैं निर्धारित अवधि/वैधता अवधि के भीतर निविदा को रद्द नहीं करूंगा या उद्धृत दरों में वृद्धि नहीं करूंगा।
I will not revoke the tender within the stipulated period/ validity period OR increase the quoted rates.
2. क्रय आदेश प्राप्त होने पर मैं काम शुरू कर दूंगा।
I will commence the work on receipt of Purchase Order.
3. मैं निविदा की वैधता अवधि के दौरान निविदा को वापस नहीं लूंगा, उसमें संशोधन नहीं करूंगा, या किसी भी प्रकार से निविदा को क्षति नहीं पहुंचाऊंगा या उसका मूल्य कम नहीं करूंगा।
I will not withdraw or amend the tender or impair or derogate from the tender in any respect within the period of validity of the tender.
4. मैं निर्दिष्ट अवधि के भीतर आवश्यक निष्पादन सुरक्षा प्रस्तुत करूंगा।
I will furnish the required performance security within the specified period.

बोली लगाने वाले का नाम और पता
NAME AND ADDRESS OF THE BIDDER

जगह PLACE:

तारीख DATE:

बोली लगाने वाले के हस्ताक्षर और मुहर
SIGNATURE AND STAMP OF THE BIDDER

भारत के साथ भूमि सीमा साझा करने वाले देशों के विक्रेताओं का डीपीआईआईटी के साथ अनिवार्य पंजीकरण

संबंधी धारा का अनुपालन

**COMPLIANCE TO CLAUSE W.R.T MANADATORY REGISTRATION OF VENDORS
FROM COUNTRIES SHARING LAND BORDER WITH INDIA, WITH DPIIT**

तारीख: Date:

जिस किसी को भी इससे सरोकार हो

TO WHOMSOEVER IT MAY CONCERNS

भारत के साथ भूमि सीमा साझा करने वाले देश के बोलीदाता से खरीद पर प्रतिबंध शीर्षक वाला खंड पढ़ा है।

"I have read The clause titled restrictions on procurement from a bidder of a country which shares a land border with India.

मैं प्रमाणित करता/करती हूँ कि मेसर्स (बोलीदाता का नाम) ऐसे देश से नहीं है

I certify that M/s.....(Name Bidder) is not from such a country

या | Or

मैं एतद्वारा प्रमाणित करता/करती हूँ कि मेसर्स (बोलीदाता का नाम) उस देश से है जिसकी सीमा भारत के साथ लगती है और वह इस संबंध में सभी आवश्यकताओं को पूरा करता है तथा विचार किए जाने के योग्य है। इसके साथ वैध पंजीकरण प्रमाणपत्र संलग्न है।

I hereby certify that M/s.(name of Bidder) is from a country which shares land border with India and fulfills all requirements in this regard and is eligible to be considered. Enclosed herewith Valid Registration Certificate

या | Or

मैं एतद्वारा प्रमाणित करता/करती हूँ कि मेसर्स (बोलीदाता का नाम) ऐसे देश से हैं जिसकी सीमा भारत के साथ लगती है। हालाँकि, पंजीकरण की यह आवश्यकता उन बोलीदाताओं पर लागू नहीं होगी जिन्हें भारत सरकार ने ऋण दिया है या जहाँ भारत सरकार परियोजनाओं के विकास में लगी हुई है। इस संबंध में दस्तावेज़ी साक्ष्य संलग्न हैं।

I hereby certify that M/s..... (Name of Bidder) is from such a country which shares land border with India , however the said requirement of registration will not be applicable to bidders as Govt. of India has extended lines of credit or in which Govt. of India is engaged in development of projects. Enclosed herewith documentary evidence in this regards

हम पुष्टि करते हैं कि यदि यह सिद्ध हो जाता है कि इस अनुबंध के लिए प्रतिस्पर्धा करते समय हमने उपरोक्त खंड के अनुसरण में कोई गलत जानकारी प्रदान की है तो हमारी बोली अस्वीकार कर दी जाएगी।

We confirm that if it is established that we have provided any false information in pursuance to above clause, while competing for this contract then our Bid shall be rejected.

हम पुष्टि करते हैं कि यदि यह सिद्ध हो जाता है कि इस अनुबंध के लिए प्रतिस्पर्धा करते समय हमने उपरोक्त खंड के अनुसरण में कोई गलत जानकारी प्रदान की है तो हमारी बोली अस्वीकार कर दी जाएगी।

We further confirms that, if it is established that we have not complied with terms of aforesaid clause, during execution of contract, this would be a sufficient ground for immediate termination of the contract as per tender provision and shall be dealt accordingly

बोली लगाने वाले का नाम Name of the Bidder

बोली लगाने वाले की मुहर और हस्ताक्षर Stamp & Signature of the Bidder